

Installation Instructions

DSM-43900DUS Altronic Universal Temperature Scanner

Form DSM-43900 II 10-21



1.0 SYSTEM DESCRIPTION

- 1.1 The Altronic DSM-43900DUS universal temperature scanner is an electronic instrument designed to monitor temperatures using industry standard type J or K thermocouples. Automatic cold junction compensation is built-in. Three models DSM-43908 (8 channels), DSM-43916 (16 channels) and DSM-43924 (24 channels) are available. The temperature scanner uses a microcontroller to process the input signal and a nonvolatile memory to store the setup and setpoint values. A 2x16 character LCD displays the channel number and the numeric temperature value in °F or °C. A front mounted keypad serves as the user interface. The instrument can read type J thermocouples between -76°F and 1382°F (-60°C and 750°C) and type K thermocouples between -76°F and +1472°F (-60°C and 800°C).
- 1.2 Each of the input channels may have 4 individual user established temperature setpoints that can be adjusted using the keypad - a high and low alarm and a high and low shutdown. Alternatively, the user may assign a selected number of channels (2 min.) to a group with a common set of 6 setpoints (high, low and differential alarm and high, low and differential shutdown) with the remaining channels having 4 individual setpoints as described in the preceding sentence. There are two configurable output switches, one for alarms and one for shutdowns. When the temperature has exceeded its setpoint value, a solid state output switch turns on/off to the switch common, and a first setpoint and channel number LCD indicators turn on. All setpoint changes are performed through the keypad or through RS-485 communications.
- 1.3 The DSM-43900DUS universal temperature scanner is designed to be versatile and simple to use. Type J or K thermocouples and °F or °C units can be selected via the keypad. Either automatic or manual scan functions can be selected. An alarm log is available for the first four faults. RS-485 serial communications allows data and alarm status to be communicated to other devices. An escape key is provided to permit the user to exit any setup function and return to the normal display. A programmable software filter is also provided which can be used to stabilize readings where the thermocouple signal is fluctuating. Calibration can be performed using the keypad. Factory default configurations, including factory calibration settings, can be recalled for easy setup.

WARNING: DEVIATION FROM THESE INSTALLATION INSTRUCTIONS MAY LEAD TO IMPROPER OPERATION OF THE MONITORED MACHINE, WHICH COULD CAUSE PERSONAL INJURY TO OPERATORS OR OTHER NEARBY PERSONNEL.

2.0 THERMOCOUPLES

- 2.1 The DSM-43900DUS universal temperature scanner is designed to operate with industry standard, grounded or ungrounded, type J or K thermocouples. Ungrounded thermocouples are recommended where possible.

3.0 MOUNTING

- 3.1 Mount the universal temperature scanner inside a control panel or to a suitable flat surface so that the display is at a convenient viewing height. A drilling template is provided.

4.0 WIRING (SEE WIRING DIAGRAMS)

- 4.1 **POWER WIRING** - Connect the power input wires, plus to terminal DC+ and minus to DC-; power requirement is 12 to 30 Vdc (0.1 amps max.). Connect the DC- terminal to panel ground which should be the same as engine ground. DO NOT ground this device directly to the ignition system common coil ground.
- 4.2 **THERMOCOUPLES AND THERMOCOUPLE EXTENSION WIRE** - Grounded or ungrounded type J or K thermocouples may be used. Use thermocouple extension wire of the same type as the thermocouple probe to connect the thermocouple to the universal temperature scanner. Use stranded thermocouple wire having a good moisture-resistant insulation such as PVC; for higher ambient temperatures, Teflon or B-fibre insulated thermocouple wire is recommended. To insure an accurate signal is transmitted to the instrument, avoid any added junctions, splices and contact with other metals. Take care not to damage the insulation when installing and take precautions against later damage from vibration, abra-

NOTE: AVOID MOUNTING THE DSM UNIVERSAL TEMPERATURE SCANNER WITH THE LCD DISPLAY FACING DIRECT SUNLIGHT. THE DISPLAY TEMPERATURE RANGE IS -22°F TO +175°F (-30°C TO +80°C).

sion, or liquids in conduits. In addition, it is essential that the following practices be adhered to:

- A. Never run thermocouple wires in the same conduit with ignition wiring or other high energy wiring such as AC line power.
- B. Keep secondary wires to spark plugs and other high voltage wiring at least eight inches (200mm) away from thermocouples and extension wiring.

4.3 **OUTPUT SWITCH WIRING** - An alarm or fault condition occurs when the temperature of a point reaches or violates one of the setpoint values. This will cause the solid state output switch to turn ON or OFF (software configurable) to the switch common terminal. Output switch 1 defaults to closed (N/C) and switch 2 to open (N/O) with the absence of power. The output switch is isolated from the DC- terminal and is rated 200V, 0.2 amp. The N/O switch has a unique internal overload current protection circuit. If an overload occurs, the internal circuitry limits current to safe levels. When the overload is removed, the output switch resumes its normal ON characteristics. These switches can be wired to an Altronic annunciator system or to pilot duty relays as shown in the wiring diagrams.

4.4 **RS-485 COMMUNICATIONS WIRING** - The DSM-43900 universal temperature scanner can communicate to other instruments, PC's or PLC's via the two serial RS-485 communication wires. Use a two conductor shielded cable of fine gauge stranded wire and connect the wires to the terminals marked RS-485 "A" and RS-485 "B". Connect to the other communication device "A" to "A"(-) and "B" to "B"(+). Connect the shield wire to the master device only.

4.5 **HAZARDOUS AREA OPERATION** - The DSM-43900DUS universal temperature scanner is CSA certified for CLASS I, DIVISION 2, GROUPS C & D areas when mounted in a suitable enclosure. The device may be operated as CLASS I, DIVISION 1, GROUPS C & D intrinsically safe, if the following conditions are met:

A. The universal temperature scanner must be powered through a CSA-certified positive polarity zener barrier rated 21 volts / 0.1 amp max. A suitable barrier is a Stahl part no. 9004/51-206-100-00; follow the installation instructions supplied with the barrier.

B. The switch outputs, if used, must be connected to the sensor inputs of an Altronic DA, or DD annunciator system with the 690 series power supply. The annunciator system must be CSA certified for the designated hazardous area.

C. The RS-485 communications must not be used for Class I, Division 1, Groups C & D intrinsically safe applications. In addition, the following requirements must be met (see NFPA standard no. 493):

1. The intrinsically safe instrument wires within the panel enclosure must be kept at least two (2) inches away from other wiring. Run the thermocouple extension wires leaving the panel in a separate conduit from all other wiring and keep them separate throughout the installation.

2. Wiring to the sensors must have a grade of insulation capable of withstanding an AC voltage of 500 volts RMS.

3. Sensor wires must be run in separate conduits and junction boxes from high voltage wires such as ignition, fuel valve, and other high voltage wiring.

4.6 **TESTING THERMOCOUPLE LEADS** - If it becomes necessary to check thermocouple to terminal strip wiring with an ohmmeter or other checker, first unplug the thermocouple connectors from the universal temperature scanner. This will prevent possible damage to the device's sensitive low voltage detection circuitry.

5.0 INITIAL OPERATION

5.1 This section allows for quick setup and installation of the DSM-43900DUS universal temperature scanner. Mount and wire the device as described in sections 3.0 and 4.0. Upon initial power up, press the SETUP key; the unit will be in the configuration mode. Press the SETUP key until the display reads "THERMOCOUPLE / J or K". Press the ▲ or ▼ (up or down arrow key) to view the thermocouple options. Press ENTER/ACK when the appropriate thermocouple type is displayed to load the default data for that type. This procedure loads the factory default calibration parameters and no additional calibration should be required.

NOTE: REFER TO FIGURES 5, 9 AND 10 FOR INTRINSICALLY SAFE HOOK-UP.

WARNING: SUBSTITUTION OF COMPONENTS MAY IMPAIR INTRINSIC SAFETY AND/OR SUITABILITY FOR CLASS I, DIV. 2, GROUPS C & D.

DO NOT DISCONNECT EQUIPMENT IN DIV. 2 ENVIRONMENT UNLESS POWER IS SWITCHED OFF OR THE AREA IS KNOWN TO BE NON-HAZARDOUS

Next, enter the configuration mode again and when the display reads either “UNITS °F” or “UNITS °C”, press the ▲ or ▼ (up or down arrow key) to select and press ENTER/ACK to accept the desired units choice. The device is now ready to accurately read temperatures.

6.0 NORMAL OPERATION

6.1 When the DSM-43900DUS universal temperature scanner is in the “normal” mode, it displays the channel number (“CH. XX”) with the temperature value in °F or °C (1st line) and (2nd line) the status of the system. The status indicators are:

“TIMER: T1 2 3 4” - TX is displayed when each of the timers is active. For example, if after a reset, timers 3 and 4 have not timed out, the display will show “T3” and “4”. This gives a visual indication that the setpoints mapped to timers 3 and 4 are still locked out (not active).

CH.01 1015°F
TIMER: T3 4

“NORMAL OPERATION” - is displayed when all of the configured setpoints are armed and being monitored on a channel with individual setpoints. On a channel within either common group 1 or 2, the average temperature of that group is displayed on the second line.

CH.13 1015°F
NORMAL OPERATION

CH.01 1015°F
AVG.1 1050°F

6.2 “ALARM: HX, LX or DX” - When the setpoints are armed and a fault occurs, “1st ALARM: CH.XX” will display on the second line to show that a fault has occurred. When the channel with a fault is displayed (channel 01 in this example), the display will show “1st ALARM HX or LX or DX” or “ALARM HX or Lx or DX” indicating that a setpoint on this channel is exceeding its setpoint. When the display is on a channel that is not faulted and with a setpoint violation in the system, the second line of the display will show “1st ALARM: CH.XX” indicating that a first alarm or fault has occurred on channel one as shown in the example below. If the channel being viewed is faulted, the fault for that channel is displayed on the second line. Any faults for the channel being displayed will be indicated: H1 (high setpoint 1), H2 (high setpoint 2), L1 (low setpoint), or L2 (low setpoint 2). In addition, the corresponding configured output(s) will activate.

CH.01 1115°F
1st ALARM: H1

CH. 06 1115°F
ALARM: H1

CH.06 998°F AL
1st ALARM: CH. 01

6.3 If a monitored thermocouple temperature falls below the minimum range of the instrument (-76°F or -60°C), the display will read “OUT OF RANGE: LX” to identify this condition. If the channel is configured for a low setpoint, the associated output switch will activate. If the thermocouple temperature exceeds the maximum range of the instrument (1382°F or 750°C for type J, 1472°F or 800°C for type K) the display will read “OUT OF RANGE: HX”. If the channel number is configured for a high setpoint, the associated output switch will activate.

NOTE: IF A THERMOCOUPLE, OR ITS WIRING, BECOMES OPEN OR DISCONNECTED FROM THE UNIVERSAL TEMPERATURE SCANNER, THE DISPLAY WILL READ “TC OPEN: HX” (THERMOCOUPLE OPEN) AND IF CONFIGURED FOR A HIGH SETPOINT, ITS CONFIGURED OUTPUT SWITCH WILL ACTIVATE. ALL CONFIGURED, UNUSED THERMOCOUPLE INPUTS MUST BE SHUNTED TO PREVENT THIS CONDITION IN NORMAL OPERATION.

7.0 BARGRAPH OPERATION

- 7.1 Two analog bargraphs are available for each channel, one between setpoints L1 and H1 and the other between L2 and H2. The bargraph's low end point is the respective low setpoint value and the high end point is the respective individual high setpoint value. To view the first bargraph, press the ESC key; the bottom line will show the bargraph between L1 and H1. Press the ESC key again to display the bargraph between L2 and H2. Press the ESC key to toggle back to the status line. There is no time-out for displaying the bargraph; it will be displayed until the ESC key is pressed. If a fault occurs in the system, the fault will be acknowledged by displaying "AL" on the top line indicating a fault is occurring. The bargraph display is shown below.



8.0 KEYPAD DESCRIPTION

- 8.1 The DSM-43900DUS universal temperature scanner contains an eight-key front keypad which is used to view or change the setpoint values and to configure and calibrate the scanner. The eight front panel keys are VIEW ALARMS, RESET, SETUP, ENTER/ACK, SETPTS, ESC, and the ▲ or ▼ (up or down arrow keys).
- 8.2 VIEW ALARMS - The VIEW ALARMS key allows the user to display the channels which in the past have exceeded their setpoints (up to the first 4 faults for each switch) in the order they occurred after a reset has been performed. This is helpful in determining which thermocouple is responsible for causing an alarm. Pressing VIEW ALARMS scrolls through the channels in the order in which the measured temperature has violated the setpoint values. The first channel that was violated will be displayed first along with the "H1", "H2", "L1" or "L2" indicators. H1 and H2 are high setpoint faults; L1 and L2 are low setpoint faults. Any other channels that have had an alarm condition after the first one will be displayed in the order that they occurred. Any channel that has not violated its setpoint value will not be displayed. After displaying all channels (up to 8 maximum) that have violated their setpoints, the display will revert back to the normal display. Pressing RESET will clear all faults. Pressing ENTER when the display asks "CLEAR ALARM FAULTS?" will clear the log, display "ALARM LOG EMPTY" and then revert back to the "normal" mode. If no faults are logged, the display will show "ALARM LOG EMPTY" and then revert back to the "normal" mode.
- 8.3 RESET - The RESET key is used to clear the alarm logs, the display fault indicators and the output switch if set to latching mode. See section 11.8 for more information on Reset.
- 8.4 SETUP - The SETUP key is used to scroll through the scanner setup menu.
- 8.5 ENTER/ACK - The ENTER/ACK key is used to save new data or a new configuration in nonvolatile memory. The setup will remain even through power-down.
- 8.6 SETPTS - The SETPTS (setpoints) key is used to view or change the setpoint values. When pressed, each setpoint description (L1,L2,H1,H2) or (L1,L2,H1,H2,D1,D2) as well as the setpoint temperature value is displayed. Refer to section 10.0 for more information. NOTE: The setpoints cannot be changed if the protection is set to "On".
- 8.7 ESC - The ESC (escape) key can be used at any time during the setup, setpoint or view alarm modes to return to the normal mode. When the ESC key is pressed in any configuration mode, any changed values are ignored (not stored in memory), the configuration returns to the previous values, and the display returns to the normal reading.
- 8.8 ▲ ▼ - The up and down arrow keys are used to increment or decrement the displayed channel and corresponding temperature value. Each press of the up arrow key increments the channel one at a time while the down arrow key decrements it. These keys also scroll through the selections in the setup mode and are used to increase or decrease values for setpoints, calibration, timer and the filter screen.

9.0 DEFAULT FACTORY SETTINGS

NOTE: WHEN OPERATING MODEL DSM-43908DUS IN THE DSM-4388 MODE, THE SETPOINT INDICATORS REFERRED TO IN SECTIONS 8.2 AND 8.6 ABOVE ARE "H1" FOR HIGH AND "L1" FOR LOW.

- 9.1 The DSM-43900DUS universal temperature scanner contains default settings that are available to the user anytime during the life of the instrument. Upon receipt, the universal temperature scanner is set to one of these settings. These default settings will provide factory calibration for both type J and K thermocouples.
- 9.2 **SELECTING A DEFAULT SETTING** - From the normal mode, press the SETUP key until the display reads either "THERMOCOUPLE / J or K". Use the \leftarrow or \rightarrow key to select either a type J or K thermocouple and press ENTER/ACK. All of the configuration parameters as well as the calibration values will automatically be reset to the factory settings for that thermocouple type
- 9.3 **DEFAULT SETTINGS** - Listed below are the factory default settings stored in permanent memory.

| | |
|------------------------|-----------------------------------------------------------|
| UNITS: | Degrees F (°F) or Degrees C (°C) |
| DISPLAY SCAN: | Manual |
| DISPLAY FILTER: | 230 out of 255 |
| NUMBER OF CHANNELS: | 8, 12 or 24 channels |
| PROTECTION STATUS: | Protection is OFF (Allow setpoints to be changed.) |
| NODE NUMBER: | 01 |
| SERIAL COMMUNICATIONS: | DSM ASCII |
| SENSE LINE: | Dry contact |
| OUTPUT SW ITCHES: | Shelf state, non-latching |
| SETPOINT VALUES: | 1000°F for highs, -76°F for lows, 200°F for differentials |
| STARTUP TIMER : | All timers = 0 minutes |
| CHECKSUM: | Checksum disabled |

WARNING: UNIT MUST BE PROPERLY CONFIGURED FOR EACH APPLICATION PRIOR TO USE.

10.0 CONFIGURATION

- 10.1 The following are the configuration headings of the universal temperature scanner. From the normal display mode, press the SETUP key to enter the configuration mode. Once in the setup mode press the SETUP key to reach any of these configuration headings. After a selection has been made, press the ENTER/ACK key; the display will read "SAVED". The new data is saved at this time. The ESC (escape) key can be used at any time to abort the configuration mode and return to the normal reading. The SETUP key can be used in second level menus to go one step back in the menu. This is a convenient way to stay in a menu when a number of items need to be set up. During configuration, the unit allows 15 seconds for first level and 60 seconds for other levels between keystrokes to change or save a new configuration. If the time lapses without a keystroke, the device will automatically return to the normal mode without making any changes. The new information is saved only if the ENTER/ACK key is pressed and the display reads "SAVED". A flowchart is provided that shows step-by-step progression through the configuration procedure.
- 10.2 "UNITS / °F or °C" - The available temperature units are °F and °C. When changing temperature units, the displayed temperature is automatically converted to the new unit value. To change the unit indicator, enter the configuration mode and press the SETUP key until the display reads either " °F " or " °C ". The previously programmed unit indicator will appear. Use the \blacktriangle or \blacktriangledown (up or down arrow key) to select one of the available units, and press ENTER/ACK to accept and save the change. The display will read "SAVED", press ESC to return to the normal mode displaying the new units selected and the numeric value converted to the selected units.
- 10.3 "AUTO SCAN" - Allows the user to display automatically, or manually, the selected number of points. The scan starts with channel 01 and progresses in numerical order to the last channel selected in configuration. In manual scan, the device continually displays the temperature value of one channel at

a time. The next channel or previous channel and corresponding temperature value is displayed with each press of the ▲ or ▼ (up or down arrow key). In auto scan, the device will display each channel number and temperature value for approximately two seconds before automatically switching to the next channel. The ▲ or ▼ (up or down arrow key) can be used in auto scan to quickly advance or descend to other channels.

- 10.4 “THERMOCOUPLE / J or K” TYPE - The instrument can read either type J or K thermocouples. Use the ▲ or ▼ (up or down arrow key) to select a thermocouple type and press ENTER/ACK to accept and save the new thermocouple type.

NOTE: Pressing ENTER/ACK will return all of the adjustable parameters, including the setpoint switch values, to factory default values. When verifying the type, press ESC to exit without reloading default values. All thermocouple inputs must be either type J or K; the inputs cannot be mixed.

- 10.5 “FILTER VALUE / 1-255” DISPLAY FILTER - The display filter can be used to stabilize the display reading of a changing input. Filtering is done in both hardware and software. The software filter is an adjustable filter; the rate of change is less for large values. The filter value is read-out in a number from 1 to 255, 1 being minimum filter value and 255 being maximum filter value. Below are some typical filter values and their effect on the display reading. Settling values are approximate times in seconds to reach 90% of new reading. Use the ▲ or ▼ (up or down arrow key) to increase or decrease the filter value and press ENTER/ACK to save the new filter value.

| | | | | | | | | | | |
|----------------|-----|-----|-----|-----|-----|-----|-----|-----|-----|-----|
| FILTER VALUE | 1 | 128 | 200 | 210 | 220 | 230 | 240 | 250 | 253 | 255 |
| SETTLING, SEC. | 1.6 | 2.0 | 2.5 | 3.5 | 4.0 | 6.0 | 11 | 30 | 58 | 176 |

- 10.6 “CALIBRATE” - For calibration procedures, see Section 12.0.
- 10.7 “SETPOINT PROTECTION / OFF or ON” - This feature allows the user an added layer of protection by preventing the setpoints from inadvertently being changed. When protection is ON, the user is able to view the setpoint values but is not able to change any of them. If an attempt is made to change the setpoint values and the ENTER key is pressed when protection is on, the display will read “LOCKED” and return to the normal display mode.
- 10.8 “NODE NUMBER / 1-99” RS-485 COMMUNICATIONS NODE NUMBER - For RS-485 serial communications, each unit must be assigned a node, or identification number, so that a DSM device can be identified by the device communicating with it. Any unique number from 1 to 99 may be used.
- 10.9 “SERIAL COMMS” - This configuration sets up the serial communication type and parameters. The selections are: DSM ASCII 9,600 baud N 8 1 or MODBUS RTU 9600, 19200, 38400, 57600 baud rate N 8 1.
- 10.10 “SENSE LINE” - All setpoints and output switches can be inhibited during start-up by using the sense line. Lock-out can occur with either an external contact closure or by sensing pulses from a pickup monitoring gear teeth. Use the ▲ or ▼ (up or down arrow key) to pick either “DRY CONTACT” or “PULSED PICKUP”.
- 10.11 “OUTPUT 1 / OUTPUT 2” OUTPUT SWITCH STATE - The options for each of the output switches are fail safe or shelf state, and latching or non-latching. Shelf state is when the outputs are in the same condition with no faults as when unpowered; fail-safe is when they are opposite. In non-latching mode, the output switch changes state when the setpoints come out of violation; in latching mode, a reset event is required to clear from the tripped state. Unpowered states for the switches are closed for SW1 and open for SW2.
- 10.12 “SET TIMERS” - There are four, individually adjustable, timers that are used for start-up delay for the setpoints. The timers are designated as T1, T2, T3, and T4. The timers each can be adjusted from 0 to 99 minutes. To adjust the timers press the SETUP key until the display reads “SET TIMERS” and use the arrow keys to select the timer to adjust and press ENTER. Use the ▲ or ▼ arrow key to set each timer value and press ENTER to save.

11.0 SETPOINTS

- 11.1 First determine whether the Group Mode is desired, and if so, how many points are required to be in the first group and how many in the second group. Enter NONE if common groups are not needed. Finally, determine how many points in total are to be utilized.

| MODEL | Points in Group 1 | Points in Group 2 | Total Points Used |
|--------------|-------------------|-------------------|-------------------|
| DSM-43908DUS | 0, or 2 to 8 | 0, or 2 to 6 | 1 to 8 |
| DSM-43916DUS | 0, or 2 to 16 | 0, or 2 to 6 | 1 to 16 |
| DSM-43924DUS | 0, or 2 to 24 | 0, or 2 to 22 | 1 to 24 |

To enter these three values from the normal display mode, press the SETPTS key followed by the SETUP key. The menu for Group 1 shown below on the left will appear. The channels in Group 1 will be the first channels, starting with channel 01. Press the ▲ or ▼ (up or down arrow key) to select the desired channel number. Press the ENTER/ACK key to save this value. Press the SETUP key to go to the menu for Group 2. The channels in the Group 2 will be the next channels to follow consecutively at the end of Group 1. All remaining channels above those in Group 2 will be individual setpoint channels.

GRP . 1 Points
CH . 01 - 16 ↑↓

GRP . 2 Points
CH . 17 - 19 ↑↓

Total Points
CH . 01 - 22 ↑↓

- 11.2 For the channels in common groups 1 and 2, there are 6 common, adjustable setpoints which can be set anywhere within the range of the scanner or OFF. The setpoints are L1 (low 1), L2 (low 2), H1 (high 1), H2 (high 2), D1 (differential 1) and D2 (differential 2). Setpoints L1, H1 and D1 will trip output switch 1, and setpoints L2, H2 and D2 will trip output switch 2. To view or change the setpoint values, press the SETPTS key. The level 1 setpoints associated with the selected group of channels will be shown. Press the ▲ or ▼ (up or down arrow key) to select another group. Press the SETPTS key to select a setpoint associated with the group displayed. The channel numbers of the group will be on the first line and the setpoint type will be on the second line. After setting the setpoints for switch 1, use the SETPTS key to move the arrow to the NEXT position on the menu which will advance the screen to the setpoints for switch 2.

CH . 01 - 16 ↑↓SETPT
→ H1 L1 D1 NEXT

Press SETPTS

CH . 01 - 16 ↑↓SETPT
→ H2 L2 D2 NEXT

- 11.3 All channels not selected for groups 1 or 2 will have four individually adjustable setpoints per channel which can be set anywhere within the range of the scanner or OFF: L1 (low 1), L2 (low 2), H1 (high 1), and H2 (high 2). Setpoints L1 and H1 will trip output switch 1 and setpoints L2 and H2 will trip output switch 2. To view or change the setpoint values, press the SETPTS key. The four setpoints associated with the currently displayed channel will be shown. Press the ▲ or ▼ (up or down arrow key) to select another channel. Press the SETPTS key to select a setpoint associated with the channel displayed. The channel number will be on the first line and the setpoint type will be on the second line.

CH . 01 ↑↓SETPOINT
→ H1 L1 H2 L2

Upon selecting a channel number and setpoint, press ENTER. The display will Read the channel number, setpoint, and the setpoint value.

CH . 01 ADJUST H1
↑↓ 984°F

**NOTE: FOR MODEL DSM-43908
IN THE DSM-4388 MODE: GROUP
SELECTION IS NOT AVAILABLE
AND THE ABOVE SCREEN WILL
INDICATE H1 AND L1 ONLY.**

To adjust the displayed value, press the ▲ or ▼ (up or down arrow key) to increase or decrease the value until the desired trip-point is reached. Press ENTER/ACK to accept and save the new value. The new setpoint value will change only if the

ENTER/ACK key is pressed. Press the ESC key to return to the normal display mode with no setpoint value change. To set the selected setpoint off (no fault display or output switch action) display the adjust setpoints screen and press the SETPTS key; the display will show "OFF", press ENTER/ACK to save. To turn it back on, again press the SETPTS and then ENTER/ACK keys.

CH . 01 H1 TIMER
 ↑↓ T4 = 02 MIN.

11.4 OUTPUT SWITCHES - Output switch 1 (SW1) is closed (N/C) with the absence of power and switch 2 (SW2) is open (N/O) with the absence of power. Each switch can be actively configured with the keypad to be either open or closed and latching or non-latching. Both switches are rated 200V, 0.2 amp max. Switch 1 is activated when the temperature of any channel's temperature exceeds either L1 (low 1) or H1 (high 1) setpoint value. Switch 2 is activated when the temperature of any channel's temperature exceeds either L2 (low 2) or H2 (high 2) setpoint value. The output switch will make an electrical connection to switch common within two seconds (see note below) with a setpoint violation. A hysteresis of 10°F or 5°C is used on all setpoints to prevent the output from rapidly turning on and off near a setpoint. The output switch, if set to non-latching, will clear when the temperature values of all configured channels are 10°F / 5°C less than any setpoint. For example, if a high 2 setpoint value is set to 900°F, the output switch will trip when the monitored temperature reaches 900°F or greater and will not clear until the input temperature is less than or equal to 890°F. If the output switch is set to LATCHING, the output switch will remain tripped until reset is initiated.

11.5 SENSE LINE - All setpoints and output switches can be controlled during start-up by using the sense line. An external contact closure or sensing pulses from a pickup monitoring gear teeth can be used. Use the SETUP key to choose either "DRY CONTACT" or "PULSED PICKUP". For a dry contact, an external contact must be provided that will connect the sense line to either the 5V OUT terminal on the back of the scanner or the supply voltage when the machine is not running. Open the contact from the positive voltage when the machine is running. For the pulsed pickup input, a magnetic pickup or a halleffect pickup can be used to sense rotation. With the sense line "INACTIVE" all the setpoints and outputs will be inactive, and the display will read one of the normal screens. When the scanner is inactive, the display will show "DEVICE NOT ARMED" on the second line of the display.

CH . 01 90°F
 DEVICE NOT ARMED

11.6 START-UP TIMERS - As stated above, the start-up timers initiate when the sense line is released or when RESET is initiated. The normal display shows the timer status on the second line by displaying the active timer(s), T1, T2, T3, and or T4. When each timer that is used times out, it will be removed from the display. After all timers time out, the status will show "ARMED", indicating all setpoints are being monitored. The start-up timers can be canceled by pressing the ENTER/ACK key, or reset to maximum programmed time by pressing the RESET key. When the start-up timers expire, all configured setpoints are active as well as the output switches.

CH . 01 900°F
 TIMER: T1 2 3 4

CH . 01 900°F
 NORMAL OPERATION

11.7 FAULT INDICATORS - When a fault occurs, the second line of the display will show that a fault has occurred in the system by displaying the first faulted channel. If the channel being displayed is not faulted, the second line will show the channel number of the first channel to fault. When the channel being viewed is

NOTE: WHEN IN THE SETPOINTS MODE, THE PREVIOUS SETPOINT VALUES ARE MONITORED, AND THE NEW VALUE IS MONITORED ONLY AFTER THE ENTER/ACK KEY IS PRESSED. IF NO KEY IS PRESSED FOR 30 SECONDS, THE DISPLAY WILL RETURN TO THE NORMAL MODE AND THE CONFIGURATION WILL REVERT BACK TO THE PREVIOUS PARAMETERS. UPON PRESSING ENTER/ACK, THE TIMER SELECT SCREEN WILL FOLLOW. TO SELECT FROM ONE OF FOUR TIMERS (T1 THRU T4) OR ZERO TIME (T0) FOR THE DISPLAYED SETPOINT, USE THE ▲ OR ▼ (UP OR DOWN ARROW KEY). NOTE: THE TIMER VALUES CAN BE ADJUSTED FROM THE SETUP MENU AS DESCRIBED IN SECTION 10.12.

NOTE: THE OUTPUT SWITCH REACTION TIME IS TIED TO THE FILTER VALUE WITH TWO SECONDS BEING THE MINIMUM. FOR OTHER REACTION TIMES SEE SECTION 10.5.

NOTE: FOR MODEL DSM-43908 IN THE DSM-4388 MODE: SW1 AND SW2 ARE CONFIGURED AS A SINGLE FORM C SWITCH WITH SW1 BEING THE NORMALLY OPEN (N.O.) SIDE AND SW2 BEING THE NORMALLY CLOSE (N.C.) SIDE IN THE NON-FAULTED STATE.

NOTE: IF THE SENSE LINE IS NOT USED, SETPOINTS AND OUTPUTS ARE ALWAYS ACTIVE.

the first channel to fault, the second line of the display will show “1st ALARM” and the setpoint that first faulted. When the channel being viewed has faulted but is not the first fault, the display will show “ALARM” and all setpoints that were violated (H1, 2, L1, 2).

CH.06 890°F
1ST ALARM: CH.01

CH.01 920°F
1ST ALARM: H1

CH.03 920°F
ALARM: H1 2

- 11.8 RESET OPERATION - Reset can be initiated in one of three ways: by pressing the RESET key, by grounding the reset terminal on the back of the unit, or by sending a reset command via the RS-485 communications. A reset operation clears the view alarms and the start-up timers and places the output switches in the non-tripped condition. Reset can be held active by either grounding the reset terminal on the back of the unit or by depressing and holding the reset button in on the front keypad. When reset is kept active, the output switch will stay in the non-faulted condition and the display will show “RESET” to inform the operator.

12.0 CALIBRATION

- 12.1 The instrument is calibrated at the factory and should not require additional calibration. However, calibration can be performed in the field many times over the life of the device. The calibration mode is used to calibrate the zero and span values. Calibration can be performed from the front keypad without disassembling the unit. A thermocouple calibrator or simulator is required to provide a calibration reference.

- 12.2 CALIBRATION PROCEDURE - Connect the appropriate thermocouple simulator, either type J or K using proper thermocouple extension wire to scanner thermocouple input channel 01. The DSM-43900DUS universal temperature scanner MUST be calibrated on channel 01 only. The calibration performed on channel 01 applies to all channels. To calibrate the universal temperature scanner, press the SETUP key until the display reads “CALIBRATE” and press ENTER/ACK. The display will read “SET LOW POINT”. Adjust the simulator for a very low reading (0°F) and press ENTER/ACK; the display will show “SAMPLING”, then “ADJUST LOW POINT”. Use the ▲ or ▼ (up or down arrow key) to increase or decrease the display reading to match the setting of the simulator and press ENTER/ACK. The display will now read “SET HI POINT”. Adjust the simulator for a very high reading (1000°F) and press ENTER/ACK; the display will show “SAMPLING”, then “ADJUST HI POINT”. Again use the ▲ or ▼ (up or down arrow key) to increase or decrease the display reading to match the simulator and press ENTER/ACK. The display will read “SAVED” and will return to the normal reading with the new calibration values stored in permanent memory.

NOTE: DURING CALIBRATION, THE UNIT ALLOWS 60 SECONDS BETWEEN KEYSTROKES TO CHANGE OR SAVE A NEW CALIBRATION. IF 60 SECONDS LAPSE WITHOUT A KEYSTROKE, THE DEVICE WILL AUTOMATICALLY RETURN TO THE NORMAL MODE WITH THE PREVIOUS VALUES. THE NEW CALIBRATION INFORMATION IS SAVED ONLY IF THE ENTER/ACK KEY IS PRESSED AND THE DISPLAY READS “SAVED”.

NOTE: BE SURE THAT THE THERMOCOUPLE TYPE AND THE UNITS (°F OR °C) OF THE CALIBRATOR MATCH THE UNITS OF THE INSTRUMENT BEFORE PERFORMING A CALIBRATION.

- 12.3 The DSM-43900DUS universal temperature scanner has a feature that allows a slight adjustment of either the zero or span values individually. This type of calibration can be used to “tweak” the readout to match that of a known value without actually performing a formal calibration procedure. This adjustment must be performed only on channel 1.

- A. ZERO ADJUSTMENT ONLY - To make a small adjustment on the zero calibration value of the universal temperature scanner, enter the calibration mode by pressing the SETUP key until the display reads “CALIBRATE” and press ENTER/ACK; the display will read “SET LO POINT”. With the standard at or near zero, press ENTER/ACK and use the ▲ or ▼ (up or down arrow key) to increase or decrease the display reading to match the standard and press ENTER/ACK. The display will read “SET HI POINT”; press the SETUP key and the display will read “SAVED” and will return to the normal reading with the new zero calibration value stored in permanent memory.
- B. SPAN ADJUSTMENT ONLY - To make a small adjustment on the span point of the universal temperature scanner, enter the calibration mode by pressing the SETUP key until the display reads “CALIBRATE” and press ENTER/

NOTE: THIS TYPE OF ADJUSTMENT WILL INVALIDATE CALIBRATION SETTINGS FROM THE PROCEDURES IN SECTION 12.2.

ACK; the display will read "SET LO POINT". Press the SETUP key and the display will read "SET HI POINT". With the standard at or near the desired span value, press ENTER/ACK and use the ▲ or ▼ (up or down arrow key) to increase or decrease the display reading to match the standard and press ENTER/ACK. The display will read "SAVED" and will return to the normal reading with the new span calibration value stored in permanent memory.

13.0 INSTRUMENT LOCKOUT

- 13.1 The DSM-43900DUS contains a lockout feature that prohibits access to the configuration menu; it does allow the operator to change from °F to °C or vice versa. To lock, press and hold the ENTER and ESC keys together and then also press the SETUP key. The display will read "LOCKED" and return to the normal mode with the configuration menu locked out. To unlock, press and hold the ENTER and ESC keys together and then press the ▲ or ▼ arrow key. The display will read "UNLOCKED" and return to the normal mode allowing configuration changes to be made.

14.0 RS-485 COMMUNICATIONS, ASCII

- 14.1 The DSM-43900DUS universal temperature scanner is part of a system that has been carefully designed to easily interface to popular computers, terminals, programmable controllers and future Altronic instruments. The data and status on any channel as well as the setpoint values can be read remotely. The setpoints can also be adjusted remotely. The first alarm fault can be displayed and then cleared. A remote reset can also be performed.
- 14.2 MASTER / SLAVE OPERATION - The DSM device RS-485 communication system is designed as a master/slave system; that is, each unit responds to its own unique address (node number) only after it is interrogated by the master (computer). One master and up to 32 slaves can communicate in the system. The units communicate with the master via a polling system. The master sends a command and only the polled slave responds. The slave modules can never initiate a communications sequence. A simple command/response protocol must be strictly observed.
- 14.3 NODE NUMBER - The node number is used in the system to identify the desired slave unit being polled. The node number can be any numeric value from 1 to 99 although only 32 devices can be served on a single communications port. This number range (1 to 99) is allowed so that if device grouping by function, or application, is desired it can be implemented using the first digit as the group or engine number and the second as the unit number. For example, 53 could be used to identify the number 3 slave unit mounted on engine number 5.
- 14.4 ASCII COMMUNICATION - When the serial communication mode is set to DSM ASCII, all communication to and from the universal temperature scanner is performed using ASCII characters. This allows the information to be processed with the "string" functions common to high level computer languages such as BASIC and C. For computers that support standard serial port interfaces, no special machine language software drivers are required. The use of the ASCII format also allows for the connection of these devices to an auto answer modem for long distance operation without the need for a local supervisory computer. The ASCII characters also make system debugging easy using standard terminal emulation software.
- 14.5 HALF DUPLEX OPERATION - The RS-485 system employed uses two wires for communication and cannot send and receive data at the same time over the same two wires making it a half duplex system. When the master is in the transmit mode, the slave is in the receive mode and visa-versa.
- 14.6 ELECTRICAL OPERATING RANGE - RS-485 is a communications standard to satisfy the need for multi-dropped systems that can operate at high speeds over long distances. RS-485 uses a balanced differential pair of wires switching from 0 to 5 volts to communicate data. RS-485 drivers can handle common mode voltages from -7 to +12 volts without loss of data, making them an excellent choice for industrial environments.

14.7 COMMUNICATIONS PARAMETERS - The following must be set by the master to communicate with the slaves:

- Baud Rate: 9600
- Data Bits: 8
- Stop Bits: 1
- Parity: None

14.8 COMMUNICATIONS WIRING - The RS-485 wiring diagram illustrates the wiring required for multiple slave unit hookup. Note that every slave unit has a direct connection to the master. This allows any one slave unit to be removed from service without affecting the operation of the other units. Every unit must be programmed with a unique address or node number, but the addition of new units or nodes can be in any order. To minimize unwanted reflections on the transmission line, the bus should be arranged as a trunk line going from one module to the next. Random structures of the transmission line should be avoided. Special care must be taken with long busses (500 feet or more) to ensure error-free operation. Long busses must be terminated with a 120 ohm resistor between the terminals marked RS-485 "A" and RS-485 "B" at the master only. The use of twisted pair shielded cable will enhance signal fidelity and is recommended. To prevent ground loops the shield should be connected to the shield terminal at the master only.

14.9 RX, TX INDICATORS - An RX and TX (receive and transmit) LED is visible on the back of the DSM-43900DUS unit to indicate when the unit is either receiving or transmitting data.

14.10 CONNECTING TO A PC - When connecting the DSM-43900DUS universal temperature scanner to the RS-232 port on a PC, an RS-232 to RS-485 converter must be used for the communication interface. See wiring diagram for details.

14.11 LOADING - RS-485 uses a balanced differential pair of wires switching from 0 to 5 volts to communicate data. In situations where many units (32 max.) are connected together on a long run, voltage drop on the communications leads becomes a major problem. Voltage drops on the RS-485 minus lead appear as a common mode voltage to the receivers. While the receivers are rated to a maximum voltage difference of ± 7 volts, -7V to +12V, a practical system should not have a voltage difference exceeding ± 3 volts under normal conditions. The wire gauge used for the connections therefore limits the maximum number of units or the maximum length of wire between units in each application. The following formula can be used as a guideline to select the appropriate wire gauge.

For 18 AWG wire No. of DSM units = $(4000) / (\text{ft of wire used})$

For 20 AWG wire No. of DSM units = $(2500) / (\text{ft of wire used})$

For 22 AWG wire No. of DSM units = $(1600) / (\text{ft of wire used})$

NOTE: THE MAXIMUM NUMBER OF UNITS CONNECTED TOGETHER IN A SYSTEM IS 32.

14.12 COMMAND STRUCTURE - The DSM units operate with a simple command/response protocol to control all functions. A command must be transmitted to the unit by the master (computer or PLC) before the slave can respond with useful data. A slave unit can never initiate a communications sequence. A variety of commands exist to fully exploit the functionality of the individual units. Communication of functions to the DSM is performed with two character ASCII command codes. The general format used for the commands is illustrated below using the READ DATA command from channel 3 of a DSM as an example. The hexadecimal values for the characters are shown only as a reference for those using low level (assembly language) decoding and will not appear on the communications terminal screen. All of the characters used in the communications protocol are standard ASCII characters and appear on the computer keyboard as shown with the exception of the "not acknowledge" (NAK) which is the industry standard "control U".

| | header | start | node | space | command | space | data | end |
|-------|--------|-------|---------|-------|---------|-------|---------|-----|
| ASCII | > | (| 0 1 | | R D | | 0 3 |) |
| HEX | 3Eh | 28h | 30h 31h | 20h | 52h 44h | 20h | 30h 33h | 29h |

COMMAND HEADER ">" (3Eh) - Each command must begin with the command header sometimes referred to as a prompt character. The ASCII character used is the ">" which means that a command message will be sent from the master to the slave.

START OF TEXT "(" (28h) - The command header must be followed by the start of text indicator.

NODE NUMBER 01 - 99 - The node number or address of the device being contacted is next. A two-digit number from 01 to 99 can be used.

SPACE (20h) - Following the node number is an ASCII space character (not printable, value 20h) to act as a delimiter between the node number and the two character command word. For the balance of this document the space character will be shown normally without a specific description of each occurrence.

COMMAND WORD "RD" (52h, 44h) - The command words are standard two letter (upper case) commands sent by the master for gathering specific information about the status of a slave. The commands are listed under STANDARD COMMANDS below.

SPACE (20h) - Following the command word is another ASCII space character to act as a delimiter between the command word and the channel number.

CHANNEL NUMBER "03" - This is the channel number in the slave unit that the information is requested from.

END OF TEXT ")" (29h) - The end of text indicator says this is the end of the command.

STANDARD COMMANDS - The standard commands available are:

| | | | |
|-----------|-----------------------------|--------------------|--------------------------------------------------------|
| RD | Read Data | >(01 RD 03) | Read value of ch3. |
| RL | Read Low value | >(02 RL 01) | Read low 2 setpoint of ch1. |
| RH | Read High value | >(15 RH 02) | Read high 2 setpoint of ch2. |
| RS | Read Setpoint | >(02 RS 01) | Reads setpoint 01. (See chart below for descriptions). |
| CS | Change Setpoint | >(15 CS 02 sxxxx.) | Change setpoint value for setpoint 02 (see below). |
| CA | Clear Alarms | >(11 CA) | Clear current alarms and alarm logs. |
| RR | Remote Reset | >(01 RR) | Reset the unit. |
| FA | First Alarm value | >(01 FA) | Read the first alarm to fault output 2. |
| F1 | First Alarm value, output 1 | >(01 F1) | Read the first alarm to fault output 1. |
| F2 | First Alarm value, output 2 | >(01 F2) | Read the first alarm to fault output 2. |

NOTE: THE FIRST NUMBER IN EACH COMMAND IS THE NODE NUMBER.

NOTES: IN THE CS SETPOINT ADJUSTMENT COMMAND, THE VARIABLE DATA IS OF THE FORM: SIGN (±) FOLLOWED BY THE FOUR MOST SIGNIFICANT DIGITS AND A DECIMAL POINT. DIGITS TO THE LEFT OF THE MOST SIGNIFICANT NON-ZERO NUMBER MUST BE FILLED WITH ZERO'S FOR PLACE HOLDERS (EX: +0325.).

A plus sign must be used for a setpoint value of zero (Ex: +0000.).

Listed are the 2 digit number codes and channel numbers corresponding to the eighty setpoints setpoint codes go from 01 to 80 and correspond as follows:

| | |
|--------------|--------------------------------|
| 01 = CH01 H1 | Channel one, high setpoint one |
| 02 = CH01 L1 | Channel one, low setpoint one |
| 03 = CH01 H2 | Channel one, high setpoint two |
| 04 = CH01 L2 | Channel one, low setpoint two |
| 05 = CH02 H1 | Channel two, high setpoint one |
| 06 = CH02 L1 | Channel two, low setpoint one |
| 07 = CH02 H2 | Channel two, high setpoint two |
| 08 = CH02 L2 | Channel two, low setpoint two |
| : | : |
| : | : |
| : | : |

96 = CH24 L2 Channel twenty four, low setpoint two
 STANDARD RESPONSES - The standard responses to the commands above are:

NOTE: THE NODE NUMBER IS LISTED FIRST IN ALL OF THE COMMANDS AND RESPONSES.

| COMMAND | RESPONSE |
|---------------------------------------------------------------------------------------------------------------------------------------------------------------------------|-----------------------------------|
| >(01 RD 03) | <(01 4392 CH03 sxxxx. DegF OK OK) |
| Node 01, unit type 43924, channel 3, x value, DegF units, switch 1's first violation (L1 or H1) status indicator, switch 2's first violation (L2 or H2) status indicator. | |
| >(02 RL 01) | <(02 CH01 sxxxx. DegF) |
| Channel 1's low 2 (L2) setpoint value, DegF units. | |
| >(15 RH 02) | <(15 CH02 sxxxx. DegF) |
| Channel 2's high 2 (H2) setpoint value, DegF units. | |
| >(02 RS 07) | <(02 07 sxxxx. DegF) |
| Reads setpoint value of setpoint code 07 (channel two, high setpoint two, as described above), DegF units. | |
| >(15 CS 03 +1195.) | <(15 CS 03) |
| Change setpoint value of setpoint code 03 (channel one, high setpoint two, as described above), to 1195 degrees . | |
| >(11 CA) | <(11 CA) |
| Clear alarms at node 11. | |
| >(01 RR) | <(01 RR) |
| Perform a remote reset at node 01. | |
| >(01 FA) | <(01 CH07 H2) |
| Ch7's high setpoint two was first to fault at node 01. (FA reads the first fault on output 2 only, L2 or H2). | |
| >(01 F1) | <(01 CH01 H1) |
| Ch1's high setpoint one was first to fault at node 01. (F1 reads the first fault on output 1 only, L1 or H1). | |
| >(01 F2) | <(01 CH20 L2) |
| Ch20's low setpoint two was first to fault at node 01. (F2 reads the first fault on output 2 only, L2 or H2). | |

SETPOINT STATUS INDICATORS FOR THE **READ DATA** RESPONSE - Each setpoint status indicator consists of two ASCII characters. The first is the setpoint indicator for switch one, the second is the setpoint indicator for switch 2. The valid status indicators for the DSM-43900 series are:

- OK No faults detected on the requested channel
- H1 A configured channel is above its setpoint for output 1
- L1 A configured channel is below its setpoint for output 1
- H2 A configured channel is above its setpoint for output 2
- L2 A configured channel is below its setpoint for output 2
- NA The channel is not being used and has been disabled in the configuration menu
- TD The channel is not yet armed

VALID RESPONSE - A command/response sequence is not complete until a valid response is received. When a slave unit receives a valid command, it interprets the command, performs the desired function and then communicates the response to the master within the specified time. The master may not initiate a new command until the response from a previous command is completed.

- A valid response can occur in three ways:
- 1) a normal response indicated by a "<" header and "(" beginning and end of text
 - 2) an error response indicated by a "\$" NAK (not acknowledged)
 - 3) a communications time-out error

Each command has an associated delay time before a response can be made from the slave unit. If the response does not occur within the time specified for

the commands as given, a communications time-out error occurs. This error is usually caused by an improper command header or possibly an improper or non-existent node sent by the master. The commands and their associated maximum response delay times are listed below.

RD, RL, RH, FA, F1, F2 commands 20 msec. max.

RS, CS, CA, RR commands 100 msec. max.

An NAK error response will be sent by the DSM-43900DUS unit when it has received a command with an error in the message. All commands must be of the format above; all letters must be uppercase. The header, start-and-end of text characters, a valid node number and spaces must be sent and correct to receive an NAK; if not, no response will be sent.

NO ALARMS RESPONSE - If view alarms memory in the unit polled is clear, the response will be: <(01 CH~~ CL)

14.13 CHECKSUMS - Two additional commands are provided so that the user may enable or disable the communication checksum routines. When enabled, the messages include an error-checking checksum that is based upon an Exclusive-Or, Modulo 100 conversion sum of the characters in the message string between and including the start of text “(“ character and the end of text “)” character. The checksum number is a decimal number that is appended to the message. The slave unit calculates the checksum of the message and compares the calculated value to the actual value it received from the master in the checksum field. If the two values are not equal, an error results and no response is sent.

CE for Checksum Enabled >(01 CE) checksum enabled for node 01

CD for Checksum Disabled >(01 CD) checksum disabled for node 01

To calculate the Exclusive-Or, Modulo 100 checksum, take the binary value of the 8 bit ASCII character “(“ and XOR it with the next binary value of the ASCII character in the string. Take the result and XOR it with the next. Continue these calculations until the end of text “)” character and that is the checksum value. If the decimal number of any of the calculations are greater than 99, use Modulo 100 math. For example, for decimal 154, use 54.

The Exclusive-Or is a binary Boolean operator. The XOR truth table is as follows:

| A | B | X |
|---|---|---|
| 0 | 0 | 0 |
| 0 | 1 | 1 |
| 1 | 0 | 1 |
| 1 | 1 | 0 |

XOR EXAMPLE FOR “(“ XORed WITH “0”:

00101000

00110000

00011000 = 24 (DECIMAL)

An example of the calculation of the checksum is below:

Command: >(01 RD 01)

| ASCII CHAR | BINARY EQUIV | CHECKSUM (DECIMAL) |
|------------|--------------|--------------------|
| > | Not used | --- |
| (| 00101000 | --- |
| 0 | 00110000 | 24 |
| 1 | 00110001 | 41 |
| SPACE | 00100000 | 9 |
| R | 01010010 | 91 |
| D | 01000100 | 31 |
| SPACE | 00100000 | 63 |
| 0 | 00110000 | 15 |
| 1 | 00110001 | 62 |
|) | 00101001 | 23 |

The checksum value will be sent at the end of the command, so the command will look like: >(01 RD 01)23

- 14.14 REMOTE OPERATOR INTERFACE(ROI), ASCII - The DSM-43900 contains a feature that allows the functions of the keypad to be accessed remotely. The returned data is that of the LCD display of the DSM-43900. This feature allows for any function that can be performed locally at the keypad to be implemented remotely. All functions that are performed remotely are seen on the LCD of the DSM-43900.

Communications are at 9600 baud, 8 data bits, no parity, 1 stop bit. (9600 8 N 1). Select DSM ASCII in the "SERIAL COMMS" menu of the DSM-43900 temperature scanner.

COMMAND: >(01 KP XXX)

01 = node number, KP = key press function, XXX = 3 digit code for each key as described below.

000 = NONE (returns current display)
 001 = RESET
 002 = VIEW ALARMS
 004 = ENTER/ACK
 008 = SETUP
 016 = ESC
 032 = SETPTS
 064 = ▲ (UP ARROW KEY)
 128 = ▼ (DOWN ARROW KEY)

RESPONSE: CR LF (16 bytes of 1st line of display) CR LF (16 bytes of 2nd line of display)

CR = Carriage Return, LF = Line Feed, 16 byte ASCII blocks of display
 The total number of returned characters is 32 bytes.

15.0 RS-485 COMMUNICATIONS, MODBUS RTU

- 15.1 The DSM-43900 series is compliant to the Modicon Modbus RTU standard. Maximum number of registers that can be read at one time is limited to 32. Maximum number of booleans that can be read at one time is limited to 256. All communications are 8 Data bits, No Parity, 1 Stop bit. The baud rate is selectable for 9600, 19200, 38400, 57,600. The MODBUS address list is on the following pages.

TIMER REGISTERS (FUNCTION CODE 1)

| ADDRESS | DESCRIPTION OF FUNCTION |
|---------|---------------------------------------|
| 00001 | CHANNEL 01 H1 TIMER SELECT BIT 0 (T1) |
| 00002 | CHANNEL 01 H1 TIMER SELECT BIT 1 (T2) |
| 00003 | CHANNEL 01 H1 TIMER SELECT BIT 2 (T3) |
| 00004 | CHANNEL 01 H1 TIMER SETPOINT ON/OFF |
| 00005 | CHANNEL 01 L1 TIMER SELECT BIT 0 (T1) |
| 00006 | CHANNEL 01 L1 TIMER SELECT BIT 1 (T2) |
| 00007 | CHANNEL 01 L1 TIMER SELECT BIT 2 (T3) |
| 00008 | CHANNEL 01 L1 TIMER SETPOINT ON/OFF |
| 00009 | CHANNEL 01 H2 TIMER SELECT BIT 0 (T1) |
| 00010 | CHANNEL 01 H2 TIMER SELECT BIT 1 (T2) |
| 00011 | CHANNEL 01 H2 TIMER SELECT BIT 2 (T3) |
| 00012 | CHANNEL 01 H2 TIMER SETPOINT ON/OFF |
| 00013 | CHANNEL 01 L2 TIMER SELECT BIT 0 (T1) |
| 00014 | CHANNEL 01 L2 TIMER SELECT BIT 1 (T2) |
| 00015 | CHANNEL 01 L2 TIMER SELECT BIT 2 (T3) |

| | |
|-------|---------------------------------------|
| 00016 | CHANNEL 01 L2 TIMER SETPOINT ON/OFF |
| 00017 | CHANNEL 02 H1 TIMER SELECT BIT 0 (T1) |
| 00018 | CHANNEL 02 H1 TIMER SELECT BIT 1 (T2) |
| 00019 | CHANNEL 02 H1 TIMER SELECT BIT 2 (T3) |
| 00020 | CHANNEL 02 H1 TIMER SETPOINT ON/OFF |
| : | : : : : : |
| 00381 | CHANNEL 24 L2 TIMER SELECT BIT 0 (T1) |
| 00382 | CHANNEL 24 L2 TIMER SELECT BIT 1 (T2) |
| 00383 | CHANNEL 24 L2 TIMER SELECT BIT 2 (T3) |
| 00384 | CHANNEL 24 L2 TIMER SETPOINT ON/OFF |
| 00385 | GROUP 01 H1 TIMER SEL. BIT 0 |
| 00385 | GROUP 01 H1 TIMER SEL. BIT 0 |
| 00386 | GROUP 01 H1 TIMER SEL. BIT 1 |
| 00387 | GROUP 01 H1 TIMER SEL. BIT 2 |
| 00388 | GROUP 01 H1 SETPOINT ON/OFF |
| 00389 | GROUP 01 L1 TIMER SEL. BIT 0 |
| 00390 | GROUP 01 L1 TIMER SEL. BIT 1 |
| 00391 | GROUP 01 L1 TIMER SEL. BIT 2 |
| 00392 | GROUP 01 L1 SETPOINT ON/OFF |
| 00393 | GROUP 01 D1 TIMER SEL. BIT 0 |
| 00394 | GROUP 01 D1 TIMER SEL. BIT 1 |
| 00395 | GROUP 01 D1 TIMER SEL. BIT 2 |
| 00396 | GROUP 01 D1 SETPOINT ON/OFF |
| 00397 | GROUP 01 H2 TIMER SEL. BIT 0 |
| 00398 | GROUP 01 H2 TIMER SEL. BIT 1 |
| 00399 | GROUP 01 H2 TIMER SEL. BIT 2 |
| 00400 | GROUP 01 H2 SETPOINT ON/OFF |
| 00401 | GROUP 01 L2 TIMER SEL. BIT 0 |
| 00402 | GROUP 01 L2 TIMER SEL. BIT 1 |
| 00403 | GROUP 01 L2 TIMER SEL. BIT 2 |
| 00404 | GROUP 01 L2 SETPOINT ON/OFF |
| 00405 | GROUP 01 D2 TIMER SEL. BIT 0 |
| 00406 | GROUP 01 D2 TIMER SEL. BIT 1 |
| 00407 | GROUP 01 D2 TIMER SEL. BIT 2 |
| 00408 | GROUP 01 D2 SETPOINT ON/OFF |
| 00409 | GROUP 02 H1 TIMER SEL. BIT 0 |
| 00410 | GROUP 02 H1 TIMER SEL. BIT 1 |
| 00411 | GROUP 02 H1 TIMER SEL. BIT 2 |
| 00412 | GROUP 02 H1 SETPOINT ON/OFF |
| 00413 | GROUP 02 L1 TIMER SEL. BIT 0 |
| 00414 | GROUP 02 L1 TIMER SEL. BIT 1 |
| 00415 | GROUP 02 L1 TIMER SEL. BIT 2 |
| 00416 | GROUP 02 L1 SETPOINT ON/OFF |
| 00417 | GROUP 02 D1 TIMER SEL. BIT 0 |

| ADDRESS | DESCRIPTION OF FUNCTION |
|---------|------------------------------|
| 00418 | GROUP 02 D1 TIMER SEL. BIT 1 |
| 00419 | GROUP 02 D1 TIMER SEL. BIT 2 |
| 00420 | GROUP 02 D1 SETPOINT ON/OFF |
| 00421 | GROUP 02 H2 TIMER SEL. BIT 0 |
| 00422 | GROUP 02 H2 TIMER SEL. BIT 1 |
| 00423 | GROUP 02 H2 TIMER SEL. BIT 2 |
| 00424 | GROUP 02 H2 SETPOINT ON/OFF |
| 00425 | GROUP 02 L2 TIMER SEL. BIT 0 |
| 00426 | GROUP 02 L2 TIMER SEL. BIT 1 |
| 00427 | GROUP 02 L2 TIMER SEL. BIT 2 |
| 00428 | GROUP 02 L2 SETPOINT ON/OFF |
| 00429 | GROUP 02 D2 TIMER SEL. BIT 0 |
| 00430 | GROUP 02 D2 TIMER SEL. BIT 1 |
| 00431 | GROUP 02 D2 TIMER SEL. BIT 2 |
| 00432 | GROUP 02 D2 SETPOINT ON/OFF |

INPUT STATUS (FUNCTION CODE 2)

| ADDRESS | DESCRIPTION OF FUNCTION |
|---------|---------------------------------|
| 10001 | RESERVED |
| 10002 | RESERVED |
| 10003 | SWITCH 2 FAULT (1 = FAULT) |
| 10004 | SWITCH 1 FAULT (1 = FAULT) |
| 10005 | GLOBAL FAULT BIT (1 = FAULT) |
| 10006 | GLOBAL ARMED BIT (1 = ARMED) |
| 10007 | SENSE BIT (1 = ACTIVE) |
| 10008 | RESET (1 = ACTIVE) |
| 10009 | CHANNEL 01 H1 ARMED (1 = ARMED) |
| 10010 | CHANNEL 01 L1 ARMED (1 = ARMED) |
| 10011 | CHANNEL 01 H2 ARMED (1 = ARMED) |
| 10012 | CHANNEL 01 L2 ARMED (1 = ARMED) |
| 10013 | CHANNEL 01 H1 FAULT (1 = FAULT) |
| 10014 | CHANNEL 01 L1 FAULT (1 = FAULT) |
| 10015 | CHANNEL 01 H2 FAULT (1 = FAULT) |
| 10016 | CHANNEL 01 L2 FAULT (1 = FAULT) |
| 10017 | CHANNEL 02 H1 ARMED (1 = ARMED) |
| 10018 | CHANNEL 02 L1 ARMED (1 = ARMED) |
| 10019 | CHANNEL 02 H2 ARMED (1 = ARMED) |
| : | : : : : : |
| 10197 | CHANNEL 24 H1 FAULT (1 = FAULT) |
| 10198 | CHANNEL 24 L1 FAULT (1 = FAULT) |
| 10199 | CHANNEL 24 H2 FAULT (1 = FAULT) |
| 10200 | CHANNEL 24 L2 FAULT (1 = FAULT) |
| 10201 | GROUP 01 D1 ARMED (1 = ARMED) |

| | |
|-------|-------------------------------|
| 10202 | GROUP 01 D2 ARMED (1 = ARMED) |
| : | : : : : : |
| 10207 | GROUP 02 D1 (1 = FAULT) |
| 10208 | GROUP 02 D2 (1 = FAULT) |

INPUT REGISTERS (FUNCTION CODE 4)

| ADDRESS | DESCRIPTION OF FUNCTION |
|---------|------------------------------------------|
| 30001 | CHANNEL 01 TEMPERATURE IN DEGREES KELVIN |
| 30002 | CHANNEL 02 TEMPERATURE IN DEGREES KELVIN |
| 30003 | CHANNEL 03 TEMPERATURE IN DEGREES KELVIN |
| 30004 | CHANNEL 04 TEMPERATURE IN DEGREES KELVIN |
| 30005 | CHANNEL 05 TEMPERATURE IN DEGREES KELVIN |
| 30006 | CHANNEL 06 TEMPERATURE IN DEGREES KELVIN |
| 30007 | CHANNEL 07 TEMPERATURE IN DEGREES KELVIN |
| 30008 | CHANNEL 08 TEMPERATURE IN DEGREES KELVIN |
| 30009 | CHANNEL 09 TEMPERATURE IN DEGREES KELVIN |
| 30010 | CHANNEL 10 TEMPERATURE IN DEGREES KELVIN |
| 30011 | CHANNEL 11 TEMPERATURE IN DEGREES KELVIN |
| 30012 | CHANNEL 12 TEMPERATURE IN DEGREES KELVIN |
| 30013 | CHANNEL 13 TEMPERATURE IN DEGREES KELVIN |
| 30014 | CHANNEL 14 TEMPERATURE IN DEGREES KELVIN |
| 30015 | CHANNEL 15 TEMPERATURE IN DEGREES KELVIN |
| 30016 | CHANNEL 16 TEMPERATURE IN DEGREES KELVIN |
| 30017 | CHANNEL 17 TEMPERATURE IN DEGREES KELVIN |
| 30018 | CHANNEL 18 TEMPERATURE IN DEGREES KELVIN |
| 30019 | CHANNEL 19 TEMPERATURE IN DEGREES KELVIN |
| 30020 | CHANNEL 20 TEMPERATURE IN DEGREES KELVIN |
| 30021 | CHANNEL 21 TEMPERATURE IN DEGREES KELVIN |
| 30022 | CHANNEL 22 TEMPERATURE IN DEGREES KELVIN |
| 30023 | CHANNEL 23 TEMPERATURE IN DEGREES KELVIN |
| 30024 | CHANNEL 24 TEMPERATURE IN DEGREES KELVIN |
| 30025 | BOX TEMP. DEGREES KELVIN |
| 30026 | CHANNEL 01 DIFF. TEMP. DEGREES KELVIN |
| 30027 | CHANNEL 02 DIFF. TEMP. DEGREES KELVIN |
| 30028 | CHANNEL 03 DIFF. TEMP. DEGREES KELVIN |
| 30029 | CHANNEL 04 DIFF. TEMP. DEGREES KELVIN |
| 30030 | CHANNEL 05 DIFF. TEMP. DEGREES KELVIN |
| 30031 | CHANNEL 06 DIFF. TEMP. DEGREES KELVIN |
| 30032 | CHANNEL 07 DIFF. TEMP. DEGREES KELVIN |
| 30033 | CHANNEL 08 DIFF. TEMP. DEGREES KELVIN |
| 30034 | CHANNEL 09 DIFF. TEMP. DEGREES KELVIN |
| 30035 | CHANNEL 10 DIFF. TEMP. DEGREES KELVIN |
| 30036 | CHANNEL 11 DIFF. TEMP. DEGREES KELVIN |

| ADDRESS | DESCRIPTION OF FUNCTION |
|---------|---------------------------------------------------------------|
| 30037 | CHANNEL 12 DIFF. TEMP. DEGREES KELVIN |
| 30038 | CHANNEL 13 DIFF. TEMP. DEGREES KELVIN |
| 30039 | CHANNEL 14 DIFF. TEMP. DEGREES KELVIN |
| 30040 | CHANNEL 15 DIFF. TEMP. DEGREES KELVIN |
| 30041 | CHANNEL 16 DIFF. TEMP. DEGREES KELVIN |
| 30042 | CHANNEL 17 DIFF. TEMP. DEGREES KELVIN |
| 30043 | CHANNEL 18 DIFF. TEMP. DEGREES KELVIN |
| 30044 | CHANNEL 19 DIFF. TEMP. DEGREES KELVIN |
| 30045 | CHANNEL 20 DIFF. TEMP. DEGREES KELVIN |
| 30046 | CHANNEL 21 DIFF. TEMP. DEGREES KELVIN |
| 30047 | CHANNEL 22 DIFF. TEMP. DEGREES KELVIN |
| 30048 | CHANNEL 23 DIFF. TEMP. DEGREES KELVIN |
| 30049 | CHANNEL 24 DIFF. TEMP. DEGREES KELVIN |
| 30050 | GROUP 01 AVG. TEMP DEGREES KELVIN |
| 30051 | GROUP 02 AVG. TEMP DEGREES KELVIN |
| 30052 | SWITCH # 1 FAULT CHANNEL (1-24 L/H, 25-48 GRP.1, 49-72 GRP.2) |
| 30053 | SWITCH # 1 FAULTED SETPOINT VALUE IN DEGREES KELVIN |
| 30054 | SWITCH # 2 FAULT CHANNEL (1-24 L/H, 25-48 GRP.1, 49-72 GRP.2) |
| 30055 | SWITCH # 2 FAULTED SETPOINT VALUE IN DEGREES KELVIN |

HOLDING REGISTERS (FUNCTION CODE 3)

| ADDRESS | DESCRIPTION OF FUNCTION |
|---------|---------------------------------------|
| 40001 | INPUT SIGNAL DISPLAY FILTER (1-255) |
| 40002 | NODE NUMBER (1-99) |
| 40003 | TIMER 1 (1-99) |
| 40004 | TIMER 2 (1-99) |
| 40005 | TIMER 3 (1-99) |
| 40006 | TIMER 4 (1-99) |
| 40007 | FAULT #1 (0 = CLEAR) |
| 40008 | FAULT #2 (0 = CLEAR) |
| 40009 | FAULT #3 (0 = CLEAR) |
| 40010 | FAULT #4 (0 = CLEAR) |
| 40011 | FAULT #5 (0 = CLEAR) |
| 40012 | FAULT #6 (0 = CLEAR) |
| 40013 | FAULT #7 (0 = CLEAR) |
| 40014 | FAULT #8 (0 = CLEAR) |
| 40015 | CHANNEL 01 SETPOINT H1 DEGREES KELVIN |
| 40016 | CHANNEL 01 SETPOINT L1 DEGREES KELVIN |
| 40017 | CHANNEL 01 SETPOINT H2 DEGREES KELVIN |
| 40018 | CHANNEL 01 SETPOINT L2 DEGREES KELVIN |
| 40019 | CHANNEL 02 SETPOINT H1 DEGREES KELVIN |
| 40020 | CHANNEL 02 SETPOINT L1 DEGREES KELVIN |
| 40021 | CHANNEL 02 SETPOINT H2 DEGREES KELVIN |

NOTE:
MODBUS DIFFERENTIAL VALUES
ARE IN DEGREES KELVIN.

DIFFERENTIAL VALUES ARE CAL-
CULATED BY THE DIFFERENCE
OF EACH OF THE HIGH - LOW
ABSOLUTE KELVIN VALUES.

| | | |
|-------|-------------------------------------------|----------|
| 40022 | CHANNEL 02 SETPOINT L2 DEGREES KELVIN | |
| : | : | : |
| 40107 | CHANNEL 24 SETPOINT H1 DEGREES KELVIN | |
| 40108 | CHANNEL 24 SETPOINT L1 DEGREES KELVIN | |
| 40109 | CHANNEL 24 SETPOINT H2 DEGREES KELVIN | |
| 40110 | CHANNEL 24 SETPOINT L2 DEGREES KELVIN | |
| 40111 | GROUP 01 SETPOINT H1 DEGREES KELVIN | OUTPUT 1 |
| 40112 | GROUP 01 SETPOINT L1 DEGREES KELVIN | OUTPUT 1 |
| 40113 | GROUP 01 SETPOINT D1 DEGREES KELVIN | OUTPUT 1 |
| 40114 | GROUP 01 SETPOINT H2 DEGREES KELVIN | OUTPUT 2 |
| 40115 | GROUP 01 SETPOINT L2 DEGREES KELVIN | OUTPUT 2 |
| 40116 | GROUP 01 SETPOINT D2 DEGREES KELVIN | OUTPUT 2 |
| 40117 | GROUP 02 SETPOINT H1 DEGREES KELVIN | OUTPUT 1 |
| 40118 | GROUP 02 SETPOINT L1 DEGREES KELVIN | OUTPUT 1 |
| 40119 | GROUP 02 SETPOINT D1 DEGREES KELVIN | OUTPUT 1 |
| 40120 | GROUP 02 SETPOINT H2 DEGREES KELVIN | OUTPUT 2 |
| 40121 | GROUP 02 SETPOINT L2 DEGREES KELVIN | OUTPUT 2 |
| 40122 | GROUP 02 SETPOINT D2 DEGREES KELVIN | OUTPUT 2 |
| 40256 | KEY COMMAND (SEND DECIMAL 21165 TO RESET) | |

15.2 IDENTIFICATION (FUNCTION CODE 17):

QUERY:

NN 17 CRC CRC

NN = node number, 17 = ID function code, CRC CRC = two byte Modbus RTU CRC.

RESPONSE:

NN 17 18 00 RC Vm M M / DD / Y Y D S M43924 CRC CRC

NN = node number, 17 = ID function code, 18 = number of bytes to follow, RC = Run Condition, VM = Version Major, Vm = Version minor, ASCII string that is the firmware date, DSM-43924 ASCII string indicating the DSM-43924 instrument, CRC CRC = two byte Modbus RTU CRC.

- 15.3 REMOTE OPERATOR INTERFACE (ROI), MODBUS, FUNCTION CODE 100 - The pyrometer contains a feature that allows the functions of the keypad to be accessed remotely in MODBUS. The returned data is that of the LCD display of the DSM-43900. This feature allows for any function that can be performed locally at the keypad to be implemented remotely. All functions that are performed remotely are seen on the LCD of the DSM-43900.

QUERY:

NN 100 KP CRC CRC

NN = node number, 100 = 3 digit ROI function code, KP = single byte key press function from table below, CRC CRC = two byte Modbus RTU CRC.

| | | |
|-----|---|--------------------------------|
| 00 | = | NONE (returns current display) |
| 01 | = | RESET |
| 02 | = | VIEW ALARMS |
| 04 | = | ENTER/ACK |
| 08 | = | SETUP |
| 16 | = | ESC |
| 32 | = | SETPTS |
| 64 | = | ▲ (UP ARROW KEY) |
| 128 | = | ▼ (DOWN ARROW KEY) |

RESPONSE:

NN 100 36 (16 bytes of 1st line of display) CR LF (16 bytes of 2nd line of display)
CR LF CRC CRC

NN = node number, 100 = 3 digit ROI function code, 36 = number of bytes to follow, CR = Carriage Return, LF = Line Feed, 2 ea. 16 byte ASCII blocks of the display, CRC CRC = two byte Modbus RTU CRC

15.4 READ COIL LABEL (FUNCTION CODE 101):

QUERY:

NN 101 ADH ADL CRC CRC

NN = node number, 101 = function code, ADH:ADL = Two byte address of desired coil (1-320), CRC CRC = two byte Modbus RTU CRC.

RESPONSE:

NN 101 30 A S C I I S T R I N G CRC CRC

NN = node number, 101 = function code, 30 = number of bytes to follow, ASCII-STRING = returned label string for the requested coil, CRC CRC = two byte Modbus RTU CRC.

15.5 READ INPUT STATUS LABEL (FUNCTION CODE 102):

QUERY:

NN 102 ADH ADL CRC CRC

NN = node number, 102 = function code, ADH:ADL = Two byte address of desired input status (1-168), CRC CRC = two byte Modbus RTU CRC.

RESPONSE:

NN 102 30 A S C I I S T R I N G CRC CRC

NN = node number, 102 = function code, 30 = number of bytes to follow, ASCII-STRING = returned label string for the requested input status, CRC CRC = two byte Modbus RTU CRC.

15.6 READ HOLDING REGISTER LABEL (FUNCTION CODE 103):

QUERY:

NN 103 ADH ADL CRC CRC

NN = node number, 103 = function code, ADH:ADL = Two byte address of desired holding register (1-94), CRC CRC = two byte Modbus RTU CRC.

RESPONSE:

NN 103 30 A S C I I S T R I N G CRC CRC

NN = node number, 103 = function code, 30 = number of bytes to follow, ASCII-STRING = returned label string for the requested holding register, CRC CRC = two byte Modbus RTU CRC.

15.7 READ INPUT REGISTER LABEL (FUNCTION CODE 104):

QUERY:

NN 104 ADH ADL CRC CRC

NN = node number, 104 = function code, ADH:ADL = Two byte address of desired input register (1-21), CRC CRC = two byte Modbus RTU CRC.

RESPONSE:

NN 104 30 A S C I I S T R I N G CRC CRC

NN = node number, 104 = function code, 30 = number of bytes to follow, ASCII-STRING = returned label string for the requested input register, CRC CRC = two byte Modbus RTU CRC.

FIGURES SECTION:

- FIG. 1 MOUNTING DIMENSIONS AND SPECIFICATIONS
- FIG. 2 DSM-43900DUS CONFIGURATION WORKSHEET
- FIG. 3 DSM-43900DUS FLOWCHART
- FIG. 4 GENERAL ELECTRICAL CONNECTIONS
- FIG. 5 WIRING DIAGRAM, ALTRONIC ANNUNCIATOR SYSTEMS
- FIG. 6 WIRING DIAGRAM, DC RELAYS
- FIGS. 7, 8 WIRING DIAGRAM, RS-485 COMMUNICATIONS
- FIGS. 9, 10, 11 WIRING DIAGRAM, SENSE LINE

FIG.1 MOUNTING DIMENSIONS AND SPECIFICATIONS, DSM-43900DUS

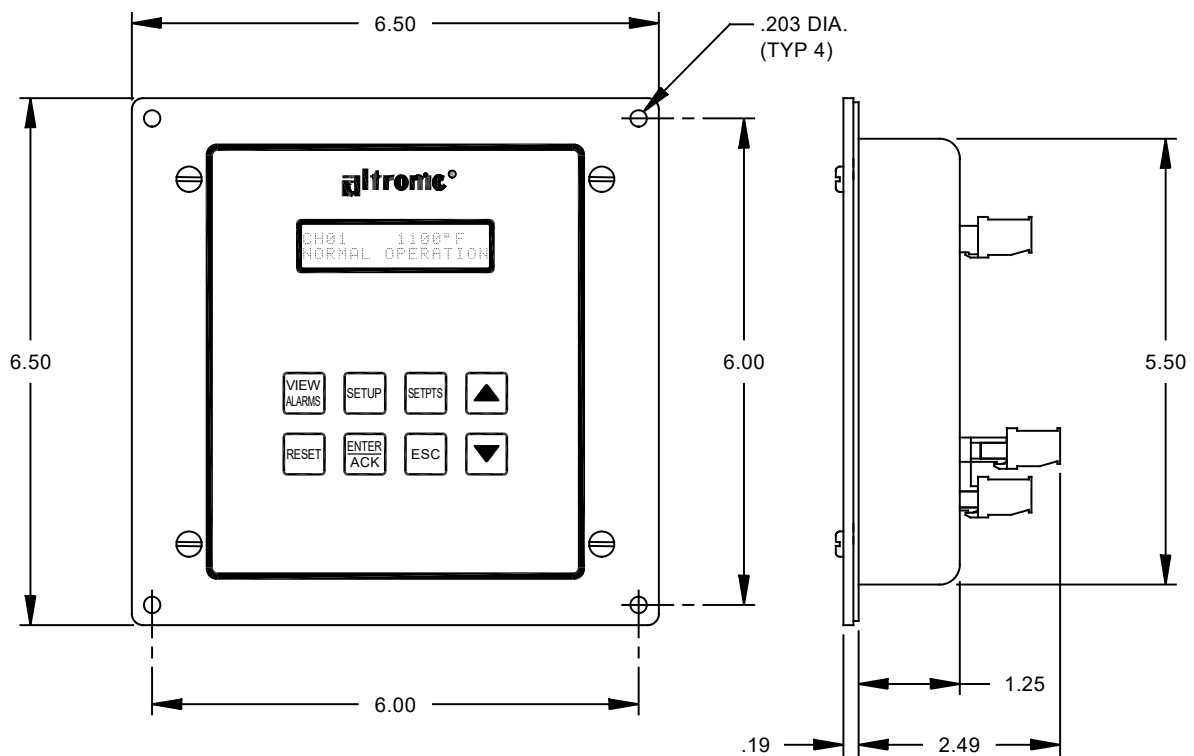

SPECIFICATIONS:

POWER REQUIRED: DC POWERED 12-30 VDC, 0.10 AMP. MAX.

THERMOCOUPLE TYPE: "J" (IRON-CONSTANTAN) OR "K" (CHROMEL-ALUMEL).

TEMPERATURE SCALE: PROGRAMMABLE °C OR °F.

DISPLAY: BACKLIT 2 X 16 LCD CHARACTER.

DISPLAY UPDATE RATE: 2 SECOND NOMINAL.

DISPLAY SCAN RATE: 2.0 SECONDS PER CHANNEL.

RANGE: TYPE "J" THERMOCOUPLE -60° TO 750°C OR -76° TO 1382°F.
 TYPE "K" THERMOCOUPLE -60° TO 800°C OR -76° TO 1472°F.

OUTPUT SWITCH: TWO PROGRAMMABLE FORM A/B (N/O, N/C) SOLID STATE SWITCHES
 RATED 200 VDC, 0.2 AMP CONTINUOUS, OPTICALLY ISOLATED
 FROM POWER SUPPLY. HYSTERESIS FIXED AT 10°F.

SWITCH RESPONSE TIME: TIED TO FILTER VALUE AND DISPLAY READING (WITH FILTER AT 1
 MAX RESPONSE TIME IS APPROXIMATELY TWO SECONDS).

AMBIENT TEMPERATURE RANGE: -40° TO 80°C (-40° TO 175°F).

INSTRUMENT ACCURACY: ±1%, ±1 DEGREE EXCLUSIVE OF THERMOCOUPLE ERROR.

HAZARDOUS AREA CLASSIFICATION: CLASS I, GROUPS C & D, DIV. 2
 CLASS I, GROUPS C & D, DIV. 1 WHEN
 POWERED FROM A CSA CERTIFIED ZENER
 BARRIER RATED 21 VOLTS/0.1 AMP MAX.

FIG.2 DSM-43900DUS CONFIGURATION WORKSHEET

SERIAL#: _____ **SITE:** _____

UNITS: _____ °F _____ °C

AUTO SCAN: _____ YES _____ NO

TYPE: _____ "J" THERMOCOUPLE _____ "K" THERMOCOUPLE

FILTER: _____ (1 = min filtering, 255 = max filtering, default = 230)

TOTAL POINTS: _____ **GROUP 1 POINTS:** _____ **GROUP 2 POINTS:** _____

SETPOINT PROTECTION: _____ ON _____ OFF

RS-485 COMMUNICATIONS NODE NUMBER: _____

SERIAL COMMUNICATIONS: _____ DSM ASCII, MODBUS RTU 9600, 19200, 38400, 57600

SENSE LINE: _____ DRY CONTACT _____ PULSED PICKUP _____ NOT USED

OUTPUT SWITCH STATE:

OUT 1 _____ SHELF _____ FAIL SAFE _____ LATCHING _____ NON-LATCHING

OUT 2 _____ SHELF _____ FAIL SAFE _____ LATCHING _____ NON-LATCHING

SET TIMERS: (minutes) T1 _____ T2 _____ T3 _____ T4 _____

SETPOINTS:

| | | | | | | | | |
|-------------|----------|---------|----------|---------|----------|---------|----------|---------|
| CH01 | H1 _____ | T _____ | L1 _____ | T _____ | H2 _____ | T _____ | L2 _____ | T _____ |
| CH02 | H1 _____ | T _____ | L1 _____ | T _____ | H2 _____ | T _____ | L2 _____ | T _____ |
| CH03 | H1 _____ | T _____ | L1 _____ | T _____ | H2 _____ | T _____ | L2 _____ | T _____ |
| CH04 | H1 _____ | T _____ | L1 _____ | T _____ | H2 _____ | T _____ | L2 _____ | T _____ |
| CH05 | H1 _____ | T _____ | L1 _____ | T _____ | H2 _____ | T _____ | L2 _____ | T _____ |
| CH06 | H1 _____ | T _____ | L1 _____ | T _____ | H2 _____ | T _____ | L2 _____ | T _____ |
| CH07 | H1 _____ | T _____ | L1 _____ | T _____ | H2 _____ | T _____ | L2 _____ | T _____ |
| CH08 | H1 _____ | T _____ | L1 _____ | T _____ | H2 _____ | T _____ | L2 _____ | T _____ |
| CH09 | H1 _____ | T _____ | L1 _____ | T _____ | H2 _____ | T _____ | L2 _____ | T _____ |
| CH10 | H1 _____ | T _____ | L1 _____ | T _____ | H2 _____ | T _____ | L2 _____ | T _____ |
| CH11 | H1 _____ | T _____ | L1 _____ | T _____ | H2 _____ | T _____ | L2 _____ | T _____ |
| CH12 | H1 _____ | T _____ | L1 _____ | T _____ | H2 _____ | T _____ | L2 _____ | T _____ |
| CH13 | H1 _____ | T _____ | L1 _____ | T _____ | H2 _____ | T _____ | L2 _____ | T _____ |
| CH14 | H1 _____ | T _____ | L1 _____ | T _____ | H2 _____ | T _____ | L2 _____ | T _____ |
| CH15 | H1 _____ | T _____ | L1 _____ | T _____ | H2 _____ | T _____ | L2 _____ | T _____ |
| CH16 | H1 _____ | T _____ | L1 _____ | T _____ | H2 _____ | T _____ | L2 _____ | T _____ |
| CH17 | H1 _____ | T _____ | L1 _____ | T _____ | H2 _____ | T _____ | L2 _____ | T _____ |
| CH18 | H1 _____ | T _____ | L1 _____ | T _____ | H2 _____ | T _____ | L2 _____ | T _____ |
| CH19 | H1 _____ | T _____ | L1 _____ | T _____ | H2 _____ | T _____ | L2 _____ | T _____ |
| CH20 | H1 _____ | T _____ | L1 _____ | T _____ | H2 _____ | T _____ | L2 _____ | T _____ |
| CH21 | H1 _____ | T _____ | L1 _____ | T _____ | H2 _____ | T _____ | L2 _____ | T _____ |
| CH22 | H1 _____ | T _____ | L1 _____ | T _____ | H2 _____ | T _____ | L2 _____ | T _____ |
| CH23 | H1 _____ | T _____ | L1 _____ | T _____ | H2 _____ | T _____ | L2 _____ | T _____ |
| CH24 | H1 _____ | T _____ | L1 _____ | T _____ | H2 _____ | T _____ | L2 _____ | T _____ |
| GP1 | H1 _____ | T _____ | L1 _____ | T _____ | D1 _____ | T _____ | H2 _____ | T _____ |
| GP2 | H1 _____ | T _____ | L1 _____ | T _____ | D1 _____ | T _____ | H2 _____ | T _____ |

FIG. 3 DSM-43900DUS - FLOWCHART

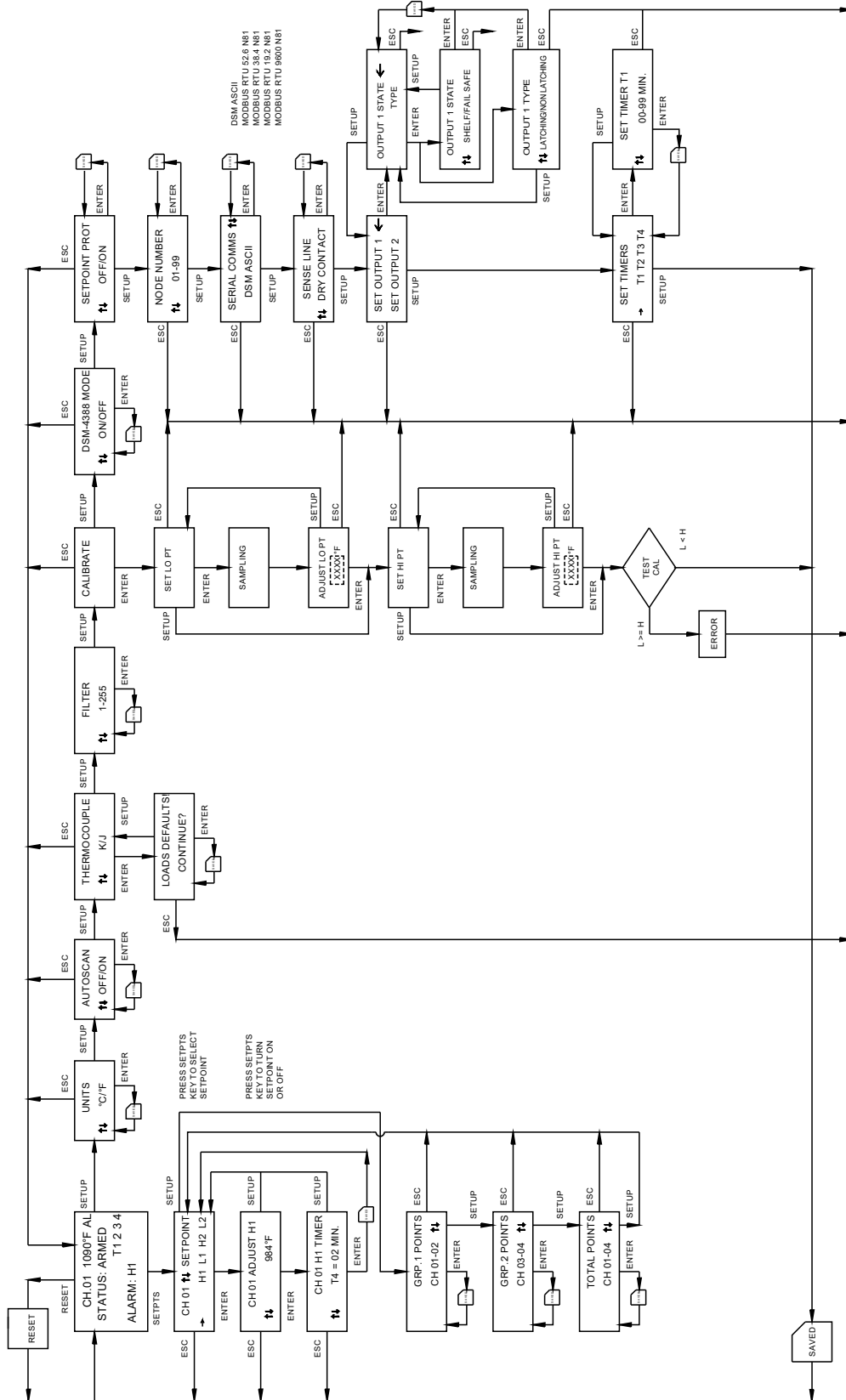

DEFAULT SETTINGS
 FOR FACTORY DEFAULT SETTINGS SELECT "F" OR "K"
 THERMOCOUPLE TYPE
 JOY-K THERMOCOUPLE
 FOR "C" UNITS
 SETPOINTS:
 1000°F
 TIMERS:
 0 MIN.
 MANUAL SCAN
 SETPOINT PROT: OFF
 NODE NUMBER: 1
 FILTER: 230
 SENSE DRY CONTACT
 OUTPUT SWITCHES: SHELF STATE
 NONLATCHING
 CHECKSUM DISABLED
 DSM ASCII

| FLOWCHART KEY | |
|---------------|--------------------------------------|
| | USE UP AND DOWN ARROW KEYS TO SCROLL |
| | |
| | |
| | |
| | ENTER |
| | ESC |
| | SETPTS |
| | RESET |
| | SAVED KEY |

FIG.4 GENERAL ELECTRICAL CONNECTIONS, DSM-43900DUS

NOTE: OUTPUT SWITCH SW1 IS CLOSED AND SW2 IS OPEN WITH ABSENCE OF POWER. EACH SWITCH IS RATED 200VDC, 0.2 AMP CONTINUOUS AND TURNS ON TO COMMON; WHICH IS ISOLATED FROM MINUS (DC-).

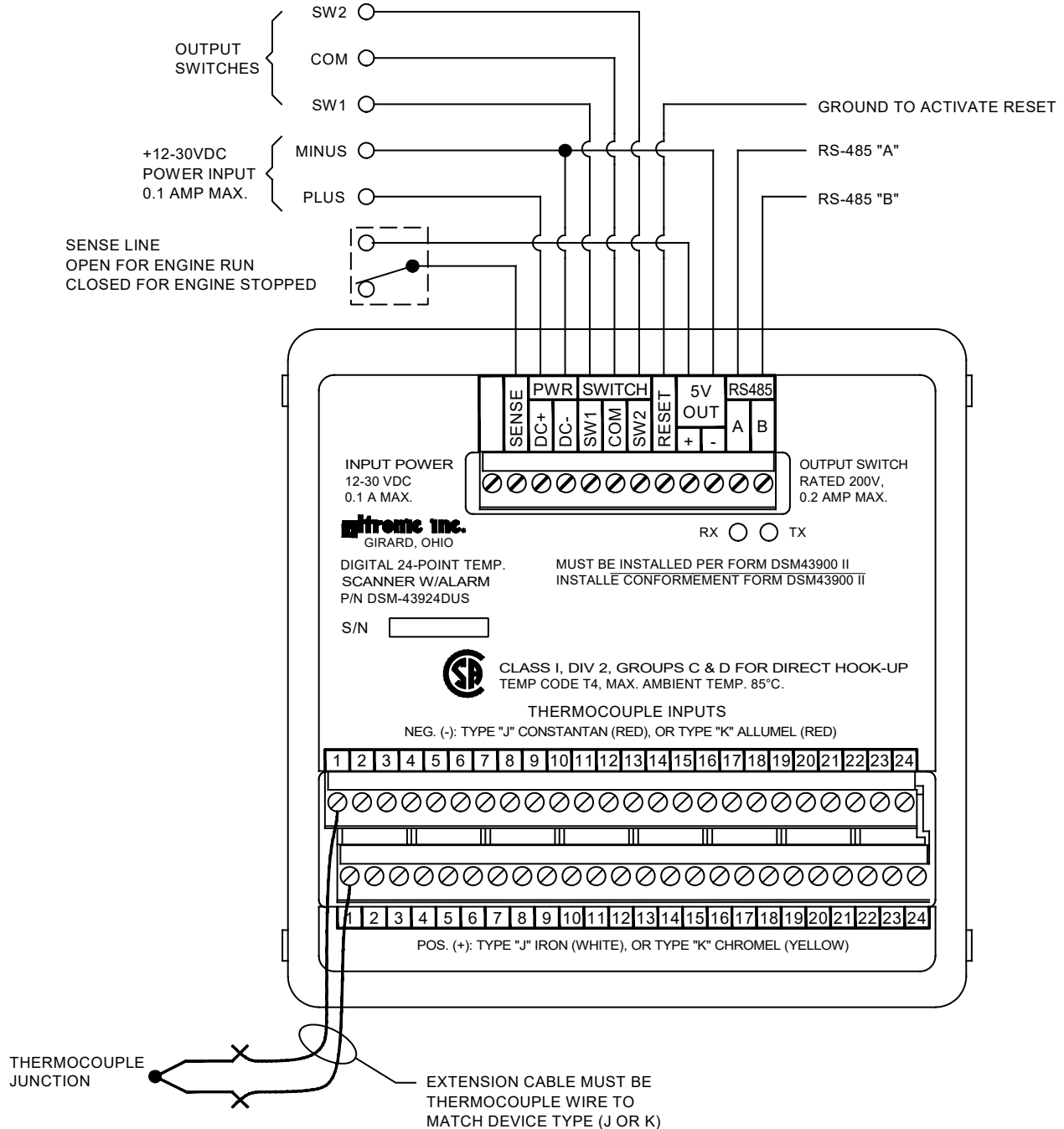

NOTES:

1. ALWAYS USE POINT 1 AND PROCEED IN SUCCESSION TO THE HIGHEST POINT REQUIRED.
2. ALL THERMOCOUPLES AND EXTENSION WIRE MUST BE OF THE SAME TYPE. ALL CONNECTIONS TO BE CLEANED, TIGHTLY TWISTED AND INSULATED WITH CERAMIC WIRE NUTS.
3. ALL UNUSED THERMOCOUPLE INPUTS MUST BE SHUNTED FOR PROPER OPERATION.
4. THERMOCOUPLES SHOULD BE EITHER ALL UNGROUNDED OR ALL GROUNDED.

FIG.5 WIRING DIAGRAM ALTRONIC ANNUNCIATOR SYSTEMS, DSM-43900DUS

NOTE: FOR INTRINSICALLY SAFE OPERATION THE FOLLOWING CONDITIONS MUST BE MET: (ALSO SEE SECTION 4.5)

1. DC POWER MUST BE FROM A CSA CERTIFIED POSITIVE POLARITY ZENER BARRIER RATED 21 VOLTS/0.1 AMP MAX. A SUITABLE BARRIER IS A STAHL PART NO. 9004/51-206-100-00; FOLLOW THE INSTALLATION INSTRUCTIONS SUPPLIED WITH THE BARRIER.
2. THE SWITCH OUTPUTS, IF USED, MUST BE CONNECTED TO THE SENSOR INPUTS OF AN ALTRONIC DA OR DD ANNUNCIATOR SYSTEM WITH 690 SERIES POWER SUPPLY.
3. THE RS-485 COMMUNICATIONS MUST NOT BE USED FOR CLASS I, DIVISION 1, GROUP D INTRINSICALLY SAFE APPLICATIONS.

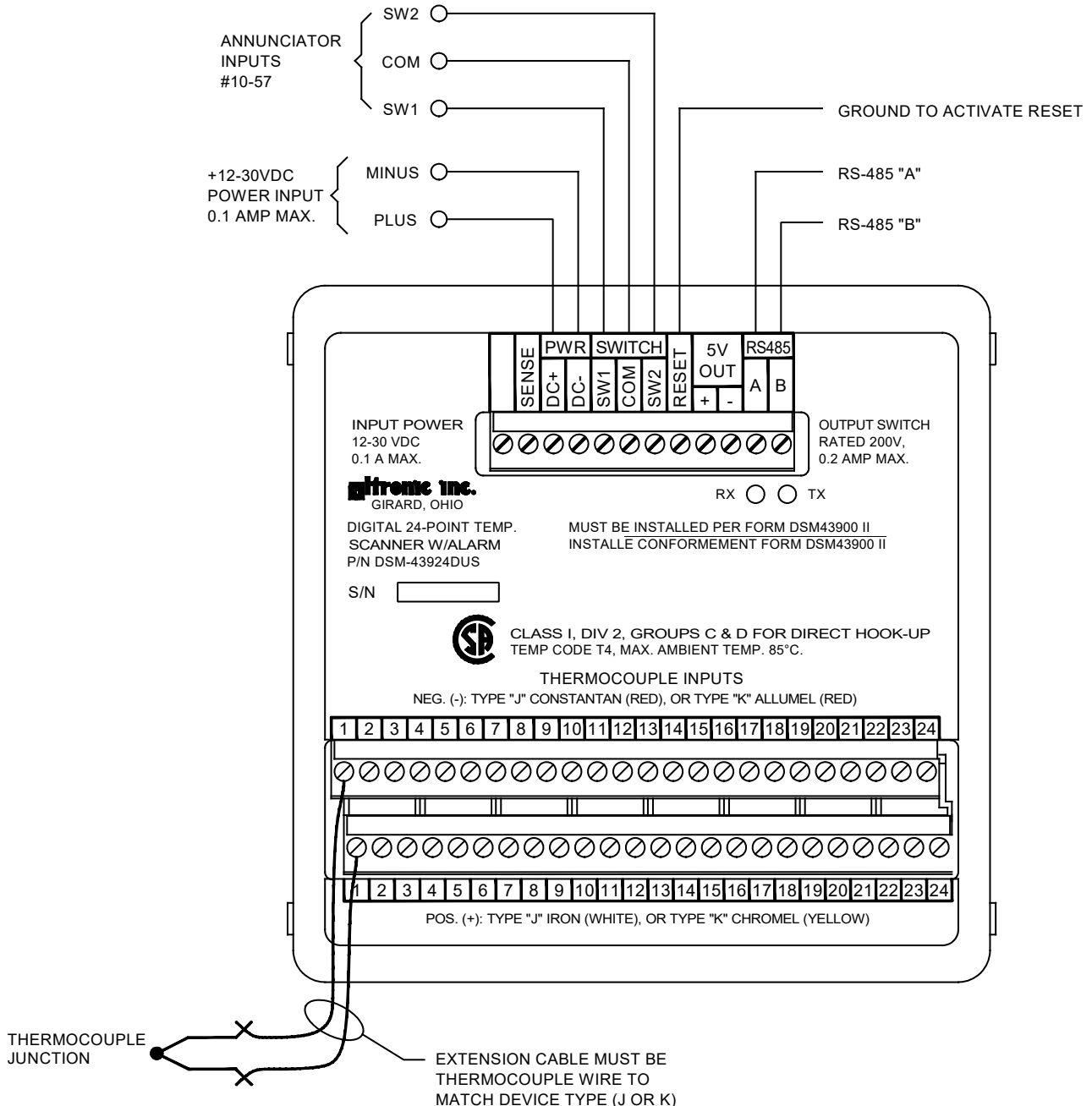

FIG.6 WIRING DIAGRAM - DC RELAY, DSM-43900DUS

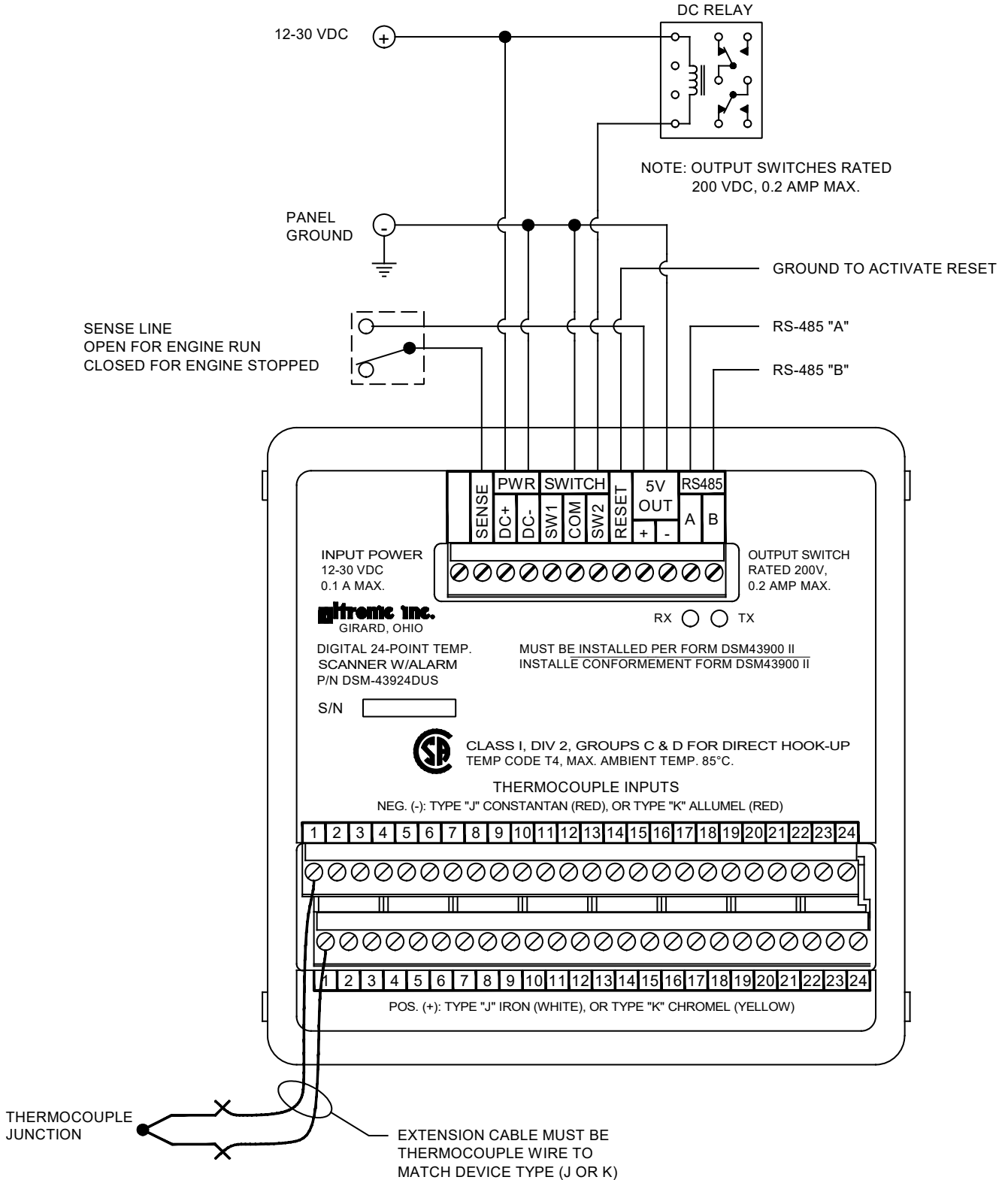

FIG.7 RS-485 COMMUNICATIONS (PC HOOK-UP)

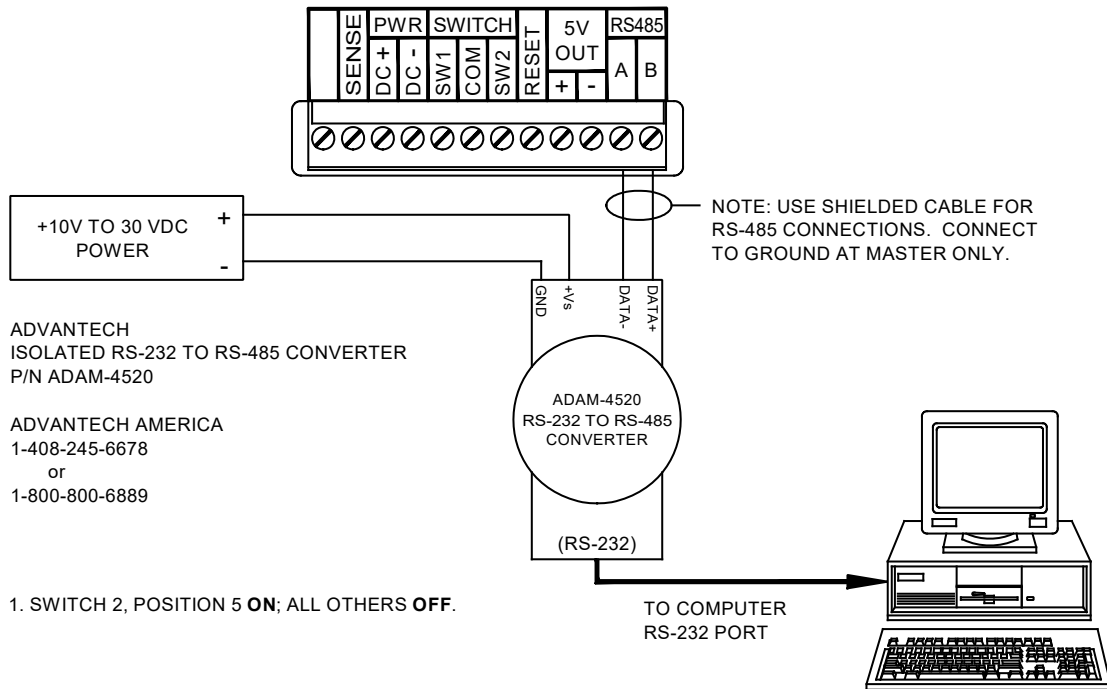
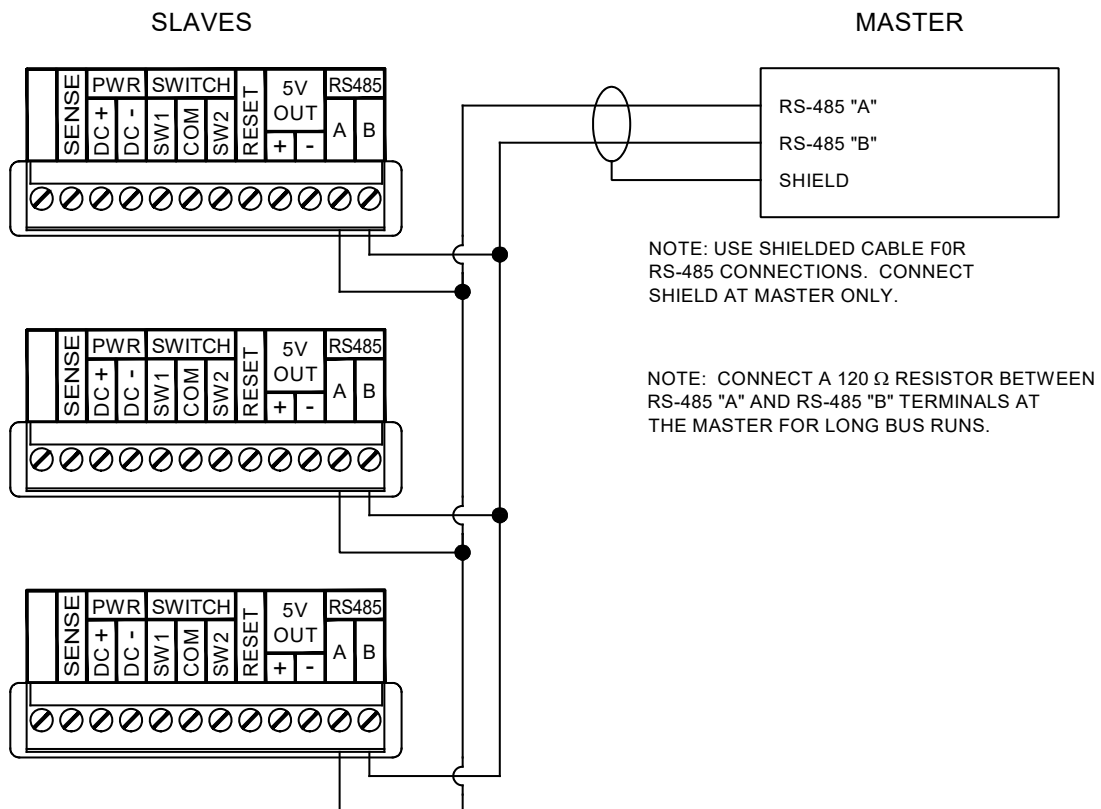

FIG.8 RS-485 COMMUNICATIONS (MULTIPLE SLAVE UNITS)



WIRING DIAGRAM - ENGINE SENSE LINE, DSM-43900DUS

FIG.9 EXTERNAL CONTACT CLOSURE - "DRY CONTACT"

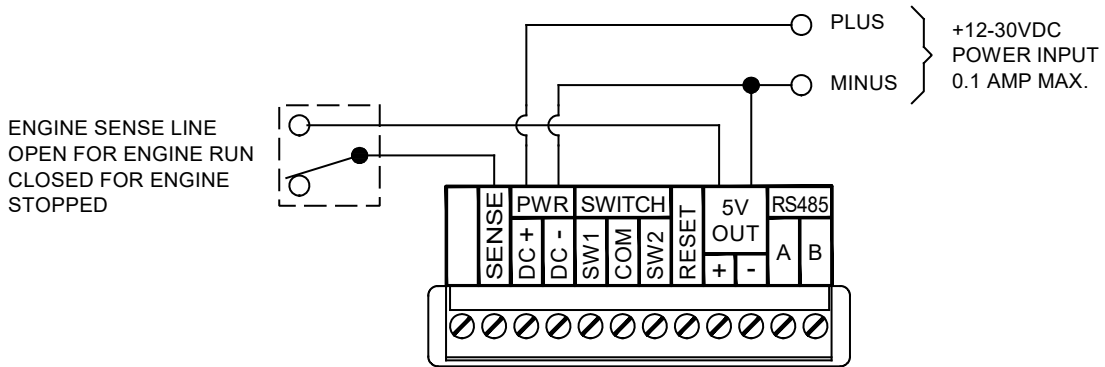

FIG.10 MAGNETIC PICKUP - "PULSED PICKUP"

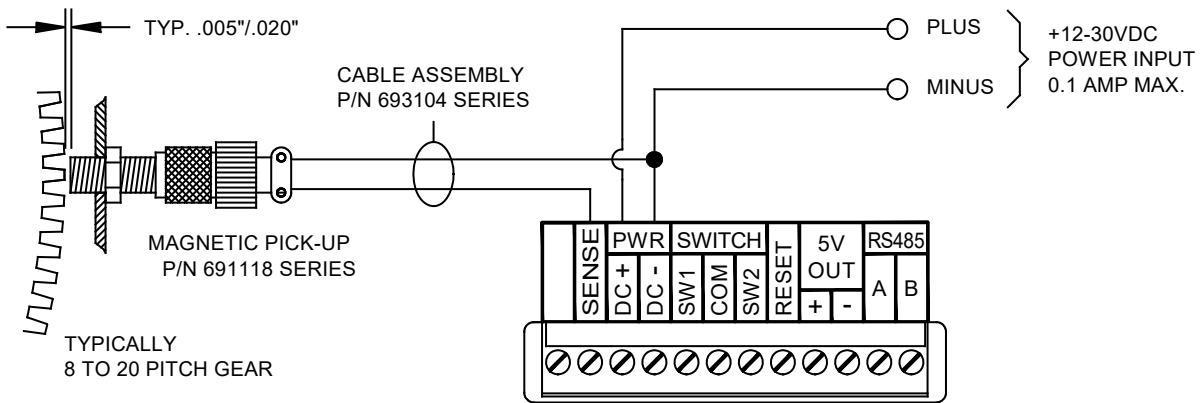

FIG.11 HALL-EFFECT PICKUP - "PULSED PICKUP"

WARNING: NOT TO BE USED FOR INTRINSICALLY SAFE INSTALLATIONS.

